

6.3a Allen-Bradley Ultra 100/200 or Electro-Craft BRU Advantage Drive with Exlar SLM Series Motors (C/P/B Connector Option)

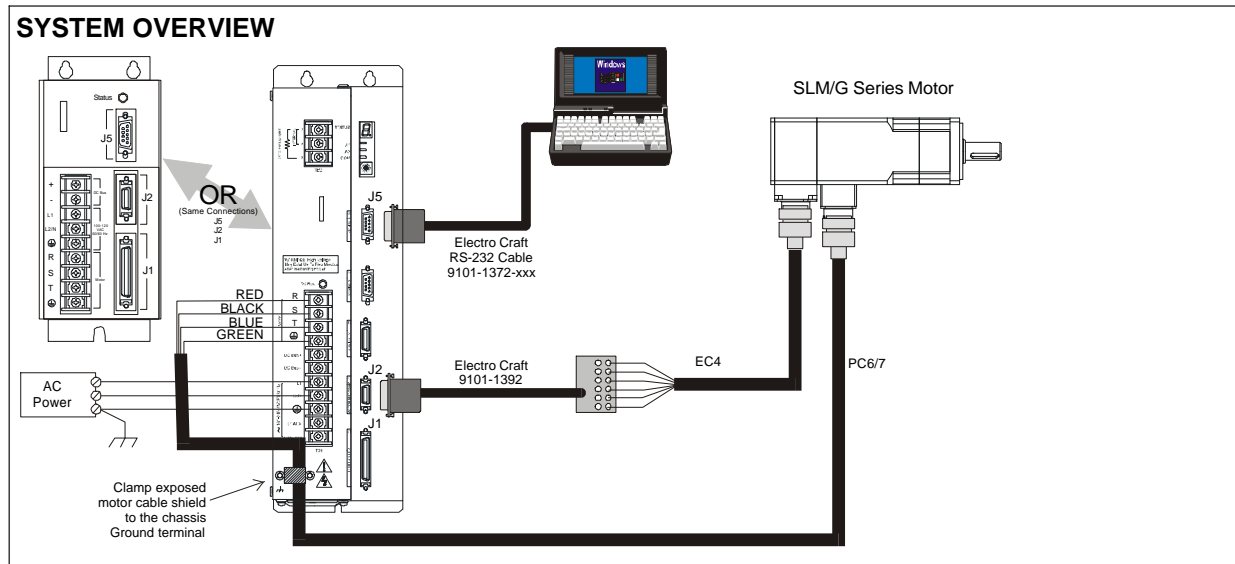

AB1 Amplifier Function	Motor Feedback Pin	EC4 Cable Colors
Motor Overtemp	A	Red/Green
A+	B	Blue
A-	C	Orange
GND	D, T	N/C
Hall C	E	White/Brown
Hall B	F	White/Gray
Hall A	G	Red/Orange
	H	Orange/Red
	J	
EPWR	K, L	Red/Blue
EPWR	L, K	
Z	M	Black
B-	N	Green
B+	P	Brown
	R	Brown/White
	S	Gray/White
GND	T, D	Blue/Red
Z-	U	Yellow
Motor Overtemp	V	Green/Red
	W	
	X	
	Y	
Shield	Z	

Motor Cable PC6-MC-XXX 060, 090 no brake lead PC7-MC-XXX size 115, no brake lead PC1-AC-XXX 060, 090 with brake lead PC7-AC-XXX size 115 with brake lead			
Exlar Connector	Wire Color	Function	DDM-XXX Connector
A	Brown	R Phase	R
B	Black	S Phase	S
C	Blue	T Phase	T
D	Green/Yellow	GND	⊕
F	Blue/White	Brake -	
G	Blue	Brake +	