

6.4a A-B/Electro-Craft Drive with Exlar PSA Series Actuators (O Connector Option)

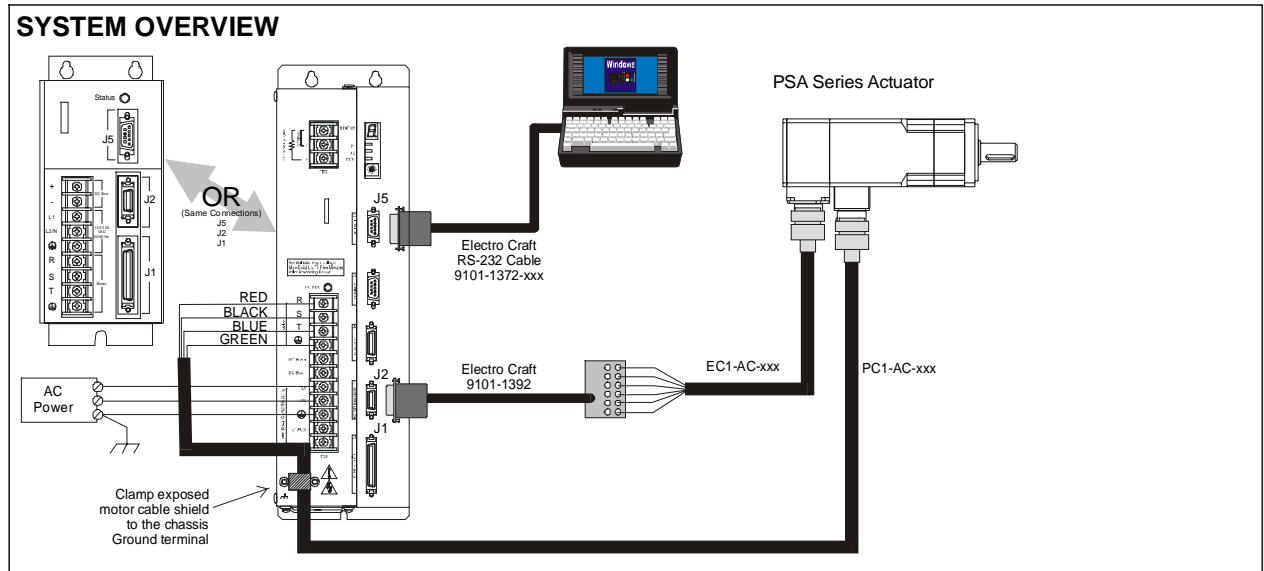

Encoder Cable EC1-AC-XXX			
Exlar Connector	Wire Color	Function	J2 Connector
T	Red	EPWR	1
J	Black	ECOM	2
G	Green	A(+)	7
H	Green/Black	A(-)	8
S	Blue/Black	B(+)	9
F	Blue	B(-)	10
E	Orange	I(+)	11
R	Orange/Black	I(-)	12
U	Blue/White	Hall A	13
K	Black/White	Hall B	14
M	Red/White	Hall C	15
	No Connection	ABS	16

Motor Cable PC1-AC-XXX			
Exlar Connector	Wire Color	Function	DDM-XXX Connector
A	Red	R Phase	R
B	Black	S Phase	S
C	Blue	T Phase	T
D	Green	GND	
F	Blue/White	Therm Sw -	J2, 20
G	Blue	Therm Sw +	J2, 19