

FT Series Linear Actuators

Exlar FT Series force tube actuators use a planetary roller screw mounted inside a telescoping tube mechanism. The follower is attached to the moveable force tube, which then extends and retracts as the screw rotates. An external motor (supplied by Exlar or the customer) provides the rotational force.

High Performance

As with all of Exlar's roller screw products, the FT Series actuators deliver heavy load capacity, high speed capabilities, and exceptionally long life when compared to other linear actuator technologies.

Other comparably-sized screw actuator products on the market - specifically ball screw and acme screw actuators - have relatively low load capacities, short working lives and limited speed capabilities. At equivalent sizes, under moderate to heavy loads, it is reasonable to project that FT units will deliver up to 15 times the working life of those other designs. For OEM designers, this often means much more power and durability can be achieved from a much smaller footprint when Exlar FT units are used.

Contamination Protection

The FT Series design has all the contamination-isolation advantages of hydraulic cylinders without the limited load, life, and speed of designs built around ball or acme screws. The bearing and roller screw components in the Exlar FT Series force tubes are mounted within the sealed housing. This prevents abrasive particles and other contaminants from entering the actuator's critical mechanisms, and assures trouble-free operation even in the most severe environments.

FT Series actuators are provided with standard grease lubrication. Custom provisions can be made for oil filled lubrication.

Engineered Compatibility

Exlar has removed much of the end-user-engineering burden by designing the FT series to be compatible with a wide variety of standard motors. Motor mounting, actuator mounting, and gearing configurations are available to meet nearly any application's requirements.

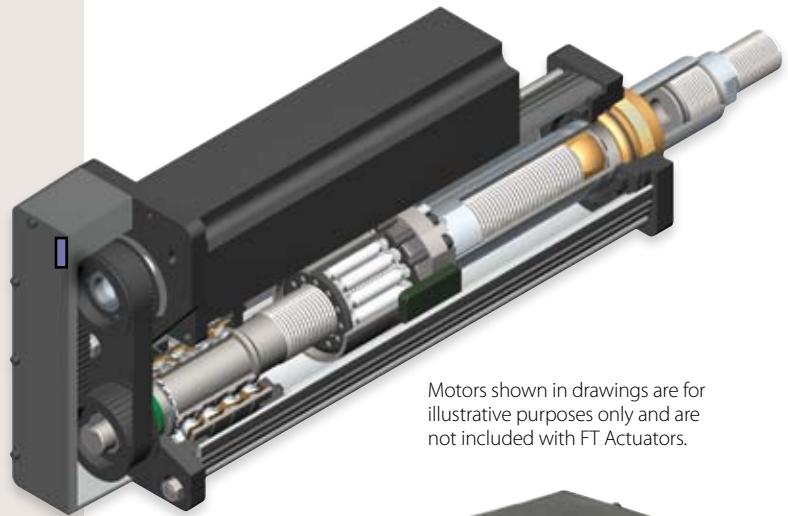

Motors shown in drawings are for illustrative purposes only and are not included with FT Actuators.



Feature	Standard	Optional
Long Strokes	12 inches to 8 feet	Intermediate & Custom Stroke Lengths
Pre-Loaded Follower	No	Yes
External Limit Switches	No	One, two or three Adjustable Switches
Multiple Actuator Mountings	Side Mount, Side Lug, Extended Tie Rods, Rear Clevis, Front Flange, Side Trunnion, Rear Flange, Front/Rear Flange	Specials Available
Multiple Motor Mounting Configurations	Inline Direct Drive, Parallel 1:1 Drive, Parallel, 2:1 Reduction	Specials Available

Special Sealing Options

The base unit of the FT actuators are sealed at the extending rod end by a rod seal, and on the drive end by a shaft seal (see base unit drawings on pages 80, 82 and 84). These rod and shaft seals, and o-ring sealing provides IP65 sealing for the FT actuator base units.

In standard units with inline, or parallel motor mounting, the mounting surface between the actuator and the motor, and between the end cover, or inline cover of the actuator and the actuator housing are not sealed as a standard feature.

These areas of the FT actuators can be sealed as a special option if the environment in which the actuator will be mounted requires the actuator to be sealed. Because of the vast differences in the design of various brands of motors that are mounted to the FT Series actuators, sealing of these two areas may alter the design of the actuator. Consult Exlar applications engineering for details and quotations on special sealing of this type.



Stainless steel FT35 with stainless steel SLM115 motor



Food grade & stainless steel FT60 with food grade SLG90 motor



Food grade & stainless steel FT35 with food grade SLM90 motor

Exlar FT Series Actuators Applications Include:

Hydraulic cylinder replacement

Ball screw replacement

Pneumatic cylinder replacement

Chip and wafer handling

Automated flexible fixturing

Dispensers

Machine tool

Automated assembly

Parts clamping

Automatic tool changers

Volumetric pumps

Medical equipment

Conveyor diverters / gates

Plastics equipment

Cut-offs

Die cutters

Packaging machinery

Entertainment

Sawmill equipment

Open / close doors

Fillers

Formers

Precision grinders

Indexing stages

Lifts

Product sorting

Material cutting

Material handling

Riveting / fastening / joining

Molding

Volumetric pumps

Semiconductor

Pick and place systems

Robot manipulator arms

Simulators

Precision valve control

Ventilation control systems

Pressing

Process control

Tube bending

Welding

Stamping

Test stands

Tension control

Web guidance

Wire winding

Food Processing

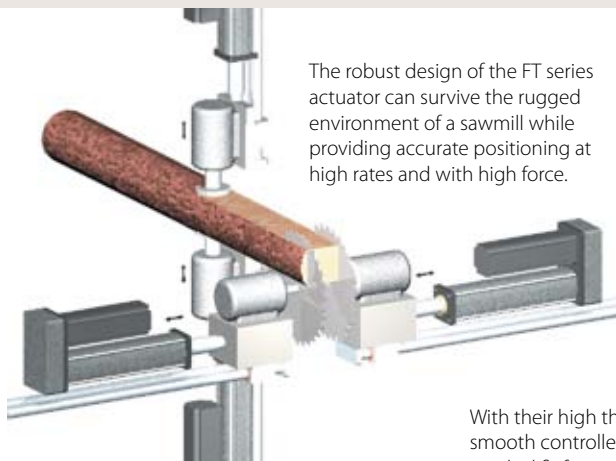

The robust design of the FT series actuator can survive the rugged environment of a sawmill while providing accurate positioning at high rates and with high force.

Motors shown in drawings are for illustrative purposes only and are not included with FT Actuators.

With their high thrust capability, compact size and smooth controlled motion, FT Series actuators are an ideal fit for replacing hydraulics or pneumatics on injection mold toggles. Control improvements from an electromechanical servo system offer less abuse of valuable molds and more consistent performance.

The smooth and accurate motion of Exlar's actuators combined with today's servo technology make multiple degree of freedom motion simulation applications easier to implement, cleaner and more efficient than hydraulic solutions.



FT Series Lifetime Curves

The L_{10} expected life of a roller screw linear actuator is expressed as the linear travel distance that 90% of properly maintained roller screws manufactured are expected to meet or exceed. For higher than 90% reliability, the result should be multiplied by the following factors: 95% x 0.62; 96% x 0.53; 97% x 0.44; 98% x 0.33; 99% x 0.21. This is not a guarantee and these charts should be used for estimation purposes only.

The underlying formula that defines this value is:

Travel life in millions of inches, where:

$$L_{10} = \left(\frac{C}{F} \right)^3 \times S =$$

C = Dynamic load rating (lbf)
F = Cubic mean applied load (lbf)
S = Roller screw's lead (inches)

All curves represent properly lubricated and maintained actuators.

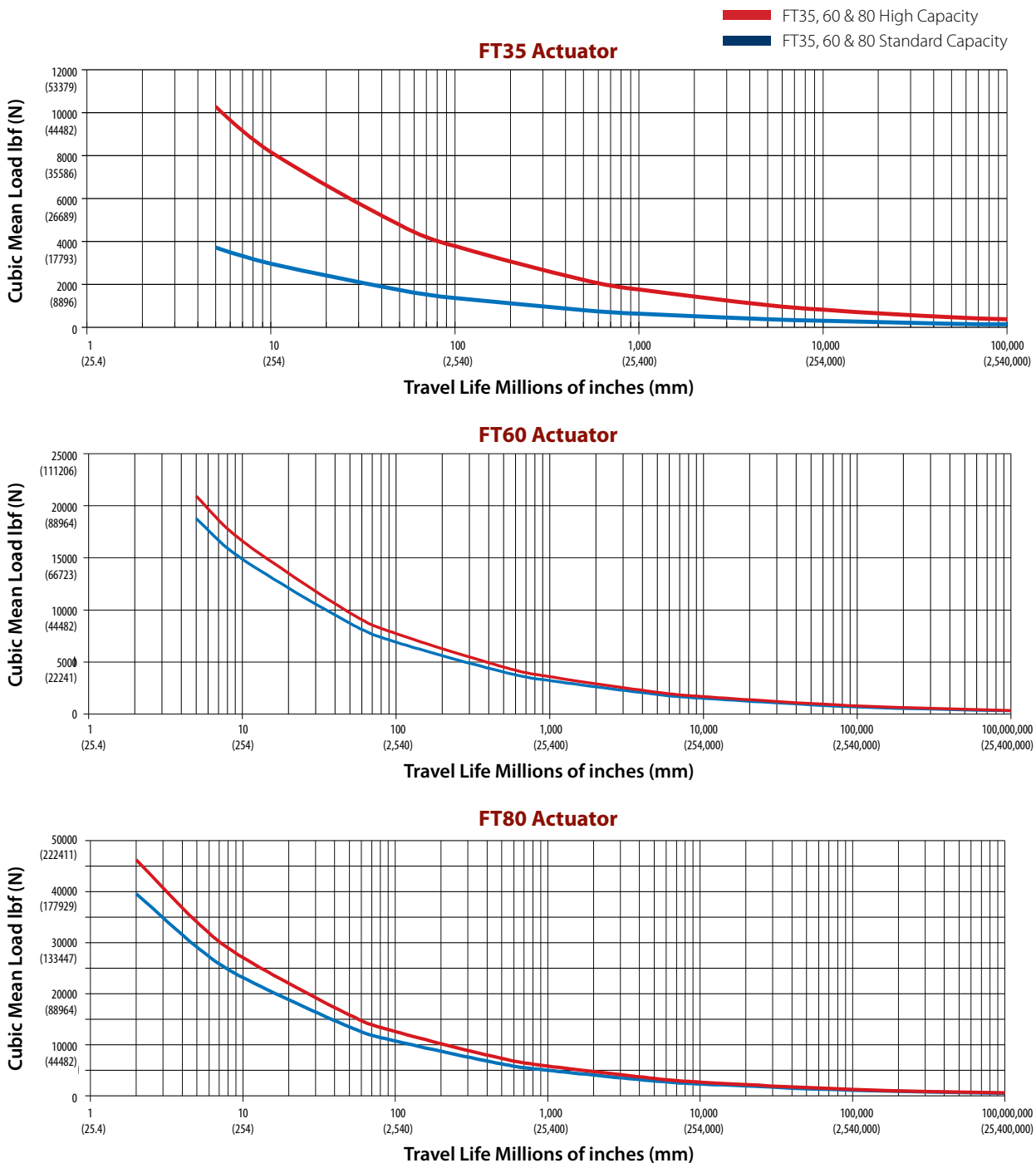

FT35 Series Performance Specifications

Model No.	Approx Frame Size in (mm)	Stroke in (mm)	Screw Lead in (mm)	Speed at Max Rated RPM in/sec (mm/sec)	Dynamic Load Rating (std. capacity) lbf (kN)	Dynamic Load Rating (high capacity) ¹ lbf (kN)	Torque @ Max. Force lb-in (N-m)	Screw Inertia lb-in-s ² (Kg-m ²)	Max Force ² lbf (kN)	Max Rated Input rpm	Weight Base lb (kg)
FT35-0605	3.5 (89)	6 (152)	0.2 (5)	14.7 (373)	10700 (47.5)	26168 (116.4)	150 (16.5)	0.0019 (0.00022)	4000 (17.8)	4500	30 (14)
FT35-0610			0.39 (10)	29.5 (750)	8700 (38.5)	21177 (94.2)	300 (33.9)				
FT35-0620			0.79 (20)	59.3 (1500)	7100 (31.5)	23987 (106.7)	600 (67.8)				
FT35-1205	3.5 (89)	12 (304)	0.2 (5)	14.7 (373)	10700 (47.5)	26168 (116.4)	150 (16.5)	0.0027 (0.00031)	4000 (17.8)	4500	35 (16)
FT35-1210			0.39 (10)	29.5 (750)	8700 (38.5)	21177 (94.2)	300 (33.9)				
FT35-1220			0.79 (20)	59.3 (1500)	7100 (31.5)	23987 (106.7)	600 (67.8)				
FT35-1805	3.5 (89)	18 (457)	0.2 (5)	14.7 (373)	10700 (47.5)	26168 (116.4)	150 (16.5)	0.0037 (0.00042)	4000 (17.8)	4500	40 (18)
FT35-1810			0.39 (10)	29.5 (750)	8700 (38.5)	21177 (94.2)	300 (33.9)				
FT35-1820			0.79 (20)	59.3 (1500)	7100 (31.5)	23987 (106.7)	600 (67.8)				
FT35-2405	3.5 (89)	24 (610)	0.2 (5)	14.7 (373)	10700 (47.5)	26168 (116.4)	150 (16.5)	0.0045 (0.00051)	4000 (17.8)	4500	45 (21)
FT35-2410			0.39 (10)	29.5 (750)	8700 (38.5)	21177 (94.2)	300 (33.9)				
FT35-2420			0.79 (20)	59.3 (1500)	7100 (31.5)	23987 (106.7)	600 (67.8)				
FT35-3605	3.5 (89)	36 (914)	0.2 (5)	8.9 (226)	10700 (47.5)	26168 (116.4)	150 (16.5)	0.0061 (0.00069)	4000 (17.8)	2700	55 (25)
FT35-3610			0.39 (10)	17.8 (452)	8700 (38.5)	21177 (94.2)	300 (33.9)				
FT35-3620			0.79 (20)	35.6 (903)	7100 (31.5)	23987 (106.7)	600 (67.8)				
FT35-4805	3.5 (89)	48 (1219)	0.2 (5)	5.7 (145)	10700 (47.5)	26168 (116.4)	150 (16.5)	0.0076 (0.00086)	4000 (17.8)	1700	65 (30)
FT35-4810			0.39 (10)	11.4 (290)	8700 (38.5)	21177 (94.2)	300 (33.9)				
FT35-4820			0.79 (20)	22.4 (568)	7100 (31.5)	23987 (106.7)	600 (67.8)				

Intermediate and custom stroke lengths are available. Intermediate leads may also be available. Belt and pulley inertia varies with ratio & motor selection. Contact Exlar's Applications Engineering Department for more information. See page 78 for definition of terms.

¹ FT35 actuators with high capacity screw option are 20 mm longer. See dimensions page 80.

² The rated and max force on the FT series actuators are those forces derived from using typical servo motors of similar frame size to the actuator, at their rated continuous and peak torques. In many cases FT actuators can be configured with input torque sufficient to exceed these forces. Contact Exlar for further details.

Pulley inertias lbf-in-sec², reflected at motor including typical pulleys, belt and standard bushings. Because of differences in belt and pulley selection due to particular motor choices, please contact Exlar's Application

FT Standard Inline Coupling Maximum Torque Ratings and Inertia

FT35	Torque Rating	Inertia
	354 lbf-in (40N-m)	0.30 lb-in s ² (0.000777 Kg-m ²)

Engineering Department if these values are critical to your application.

FT35 3 inch motor 1:1 = 0.004874

FT35 3 inch motor 2:1 = 0.002087

FT35 4 inch motor 1:1 = 0.009993

FT35 4 inch motor 2:1 = 0.005003

FT60 Series Performance Specifications

Model No.	Approx Frame Size in (mm)	Stroke in (mm)	Screw Lead in (mm)	Speed at Max. Rated RPM in/sec (mm/sec)	Dynamic Load Rating (std. capacity) lbf (kN)	Dynamic Load Rating (high capacity) lbf (kN)	Torque @ Max. Force lb-in (N-m)	Screw Inertia lb-in-s ² (Kg-m ²)	Max. Force* lbf (kN)	Max. Rated Input rpm	Weight Base lb (kg)						
FT60-1206	6.0 (152)	12 (305)	0.23 (6)	7.9 (201)	51900 (231)	57933 (257.7)	920 (103.9)	0.0454 (0.0051)	20,000 (90.8)	2000	100 (45)						
FT60-1212			0.47 (12)	15.8 (401)	44600 (199)	49750 (221.3)	1720 (194.3)										
FT60-1230			1.18 (30)	39.0 (1000)	41700 (186)	63958 (284.5)	4400 (497.1)										
FT60-2406		24 (610)	0.23 (6)	7.9 (201)	51900 (231)	57933 (257.7)	920 (103.9)	0.073 (0.0083)			20,000 (90.8)	2000	130 (59)				
FT60-2412			0.47 (12)	15.8 (401)	44600 (199)	49750 (221.3)	1720 (194.3)										
FT60-2430			1.18 (12)	39.0 (1000)	41700 (186)	63958 (284.5)	4400 (497.1)										
FT60-3606		36 (914)	0.23 (6)	7.9 (201)	51900 (231)	57933 (257.7)	920 (103.9)	0.1 (0.0113)					20,000 (90.8)	2000	160 (72)		
FT60-3612			0.47 (12)	15.8 (401)	44600 (199)	49750 (221.3)	1720 (194.3)										
FT60-3630			1.18 (30)	39.0 (1000)	41700 (186)	63958 (284.5)	4400 (497.1)										
FT60-4806		48 (1219)	0.23 (6)	7.9 (201)	51900 (231)	57933 (257.7)	920 (103.9)	0.126 (0.0142)							20,000 (90.8)	2000	190 (86)
FT60-4812			0.47 (12)	15.8 (401)	44600 (199)	49750 (221.3)	1720 (194.3)										
FT60-4830			1.18 (30)	39.0 (1000)	41700 (186)	63958 (284.5)	4400 (497.1)										

Intermediate and custom stroke lengths are also available. Intermediate leads may also be available. Belt and pulley inertia varies with ratio and motor selection.

*The rated and max force on the FT series actuators are those forces derived from using typical servo motors of similar frame size to the actuator, at their rated continuous and peak torques. In many cases FT actuators can be configured with input sufficient to exceed these forces. Contact Exlar for further details.

Pulley inertias lbf-in-sec², reflected at motor including typical pulleys, belt and standard bushings. Because of differences in belt and pulley selection due to particular motor choices, please contact Exlar's Application

FT Standard Inline Coupling Maximum Torque Ratings and Inertia

FT60	Torque Rating	Inertia
	885 lbf-in (100N-m)	0.90 lb-in-s ² (0.002331 Kg-m ²)

Engineering Department if these values are critical to your application.

FT60 1:1 = 0.030000 FT60 2:1 = 0.035000

DEFINITIONS:

Max Linear Speed: The linear speed achieved by the actuator at a screw speed equal to the max rotational speed value.

Rated Force: The linear force produced by the actuator at the torque at the rated force value.

Dynamic Load Rating: A design constant used in calculating the estimated travel life of the roller screw. The dynamic mean load is the mean load at which the device will perform one million revolutions.

Torque at Rated Force: The torque required at the screw to produce the force rating.

Screw Inertia: The rotary inertia of the planetary roller screw in the actuator.

Max. Rot. Speed: The maximum allowable rotational screw speed determined by the screw length or the rotational speed limit of the roller screw nut.

FT80 Series Performance Specifications

Model No.	Approx Frame Size in (mm)	Stroke in (mm)	Screw Lead in (mm)	Speed at Max. Rated RPM in/sec (mm/sec)	Dynamic Load Rating (std. capacity) lbf (kN)	Dynamic Load Rating (high capacity) lbf (kN)	Torque @ Max. Force lb-in (N-m)	Screw Inertia lb-in-s ² (Kg-m ²)	Max. Force* lbf (kN)	Max. Rated Input rpm	Weight Base lb (kg)	
FT80-1206	8.0 (203)	12 (305)	0.23 (6)	6.9 (175)	80700 (358)	94330 (419.6)	1950 (220.3)	0.1630 (0.0184)	40,000 (178)	1750	190 (86)	
FT80-1212			0.47 (12)	13.8 (351)	70200 (312)	84079 (374.0)	3550 (401.1)					
FT80-1230			1.18 (30)	34.4 (875)	64700 (288)	95971 (426.9)	8840 (998.8)					
FT80-2406		24 (610)	0.23 (6)	6.9 (175)	80700 (358)	94330 (419.6)	1950 (220.3)	0.247 (0.0279)				265 (120)
FT80-2412			0.47 (12)	13.8 (351)	70200 (312)	84079 (374.0)	3550 (401.1)					
FT80-2430			1.18 (12)	34.4 (875)	64700 (288)	95971 (426.9)	8840 (998.8)					
FT80-3606		36 (914)	0.23 (6)	6.9 (175)	80700 (358)	94330 (419.6)	1950 (220.3)	0.331 (0.0374)			340 (153)	
FT80-3612			0.47 (12)	13.8 (351)	70200 (312)	84079 (374.0)	3550 (401.1)					
FT80-3630			1.18 (30)	34.4 (875)	64700 (288)	95971 (426.9)	8840 (998.8)					
FT80-4806		48 (1219)	0.23 (6)	6.9 (175)	80700 (358)	94330 (419.6)	1950 (220.3)	0.415 (0.0468)				415 (187)
FT80-4812			0.47 (12)	13.8 (351)	70200 (312)	84079 (374.0)	3550 (401.1)					
FT80-4830			1.18 (30)	34.4 (875)	64700 (288)	95971 (426.9)	8840 (998.8)					

Intermediate and custom stroke lengths are also available. Intermediate leads may also be available. Belt and pulley inertia varies with ratio and motor selection. Please contact Exlar's Applications Engineering Department for more information. See page 78 for definitions of terms.

*The rated and max force on the FT series actuators are those forces derived from using typical servo motors of similar frame size to the actuator, at their rated continuous and peak torques. In many cases FT actuators can be configured with input torque sufficient to exceed these forces. Contact Exlar for further details.

Pulley inertias lbf-in-sec², reflected at motor including typical pulleys, belt and standard bushings. Because of differences in belt and pulley selection due to particular motor choices, please contact Exlar's Application

FT Standard Inline Coupling Maximum Torque Ratings and Inertia	
FT80	Torque Rating
	1770 lbf-in (200N-m)

Engineering Department if these values are critical to your application.

FT80 1:1 = 0.235000 FT80 2:1 = 0.157000

FT Series Mechanical Specifications

Model No.	FT35, FT60, FT80
Roller Screw Backlash in (mm)	0.0004 - 0.001 (0.01 - 0.03)
Preloaded Loader Screw Backlash	0
System Backlash* in (mm)	0.002 (0.06)
Standard Lead Accuracy** in/ft (mm/mm)	0.001 (.025/300)
Dynamic Torque Values lbf in/krpm (nm/krpm)	FT35: 6.0 (0.68) FT60: 11.0 (1.24) FT80: 20.0 (2.26)
Friction Torque Values lbf in (nm)	FT35: 7.0 (0.79) FT60: 14.0 (1.58) FT80: 35.0 (3.95)
Maximum Radial Load	0
Environmental Rating (Base Unit Only)***	IP65 Standard
Case:	Epoxy-coated aluminum
Standard Optional	Food Grade Coating

* System backlash will be different with various types of motor mounting arrangements and couplings. Please discuss your particular configuration with Exlar application engineers.

** Optional lead accuracy – from 0.0002 in/ft (6 μm/300 mm) to 0.002 in/ft (200 μm/10000 mm) – are also available.

*** For IP65 scaling of unit with motor mounted, please contact Exlar's Applications Engineering Department for more information and ordering information.

FT35 Series Linear Actuators

Base Unit

All dimensions shown in inches with millimeter equivalent in brackets.
See rod ends for rod end thread details.

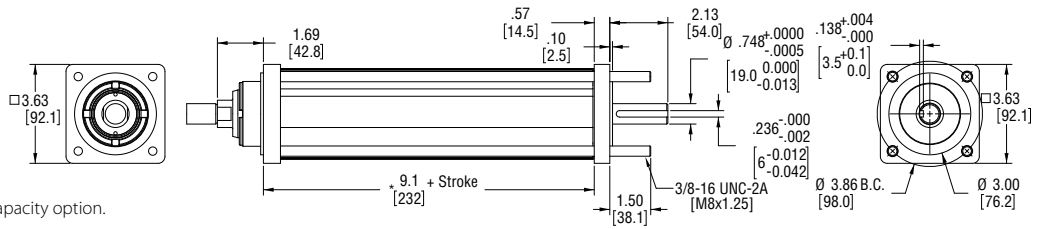

*Add 20mm if choosing high capacity option.

Clevis Mount Unit

Parallel motor mount shown.

All dimensions shown in inches with millimeter equivalent in brackets.
See rod ends for rod end thread details.

Motor plate and cover dimensions are subject to change depending on the motor selection.

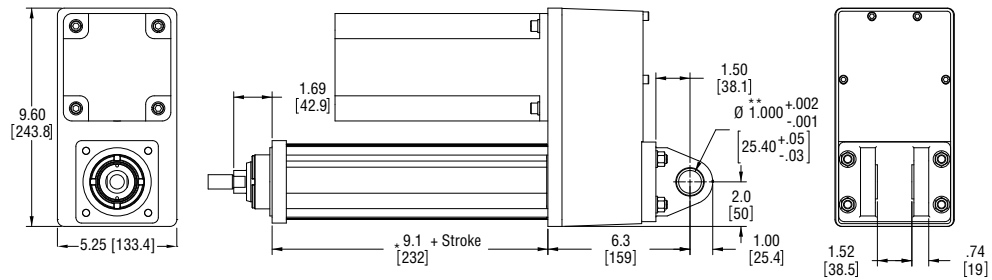

*Add 20mm if choosing high capacity option.
* If "G" metric clevis option, $\varnothing 27$ mm + 0.00 / - 0.06

Front Flange Unit

Parallel motor mount shown.

All dimensions shown in inches with millimeter equivalent in brackets.
See rod ends for rod end thread details.
Motor plate and cover dimensions are subject to change depending on the motor selection.

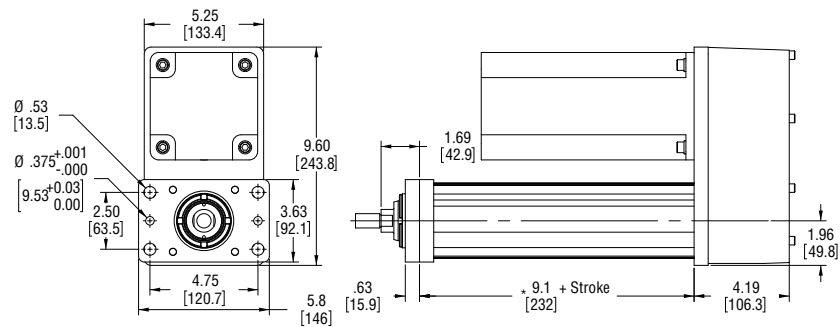

*Add 20mm if choosing high capacity option.

Rear Flange Unit

Parallel motor mount shown.

All dimensions shown in inches with millimeter equivalent in brackets.
See rod ends for rod end thread details.

Motor plate and cover dimensions are subject to change depending on the motor selection.

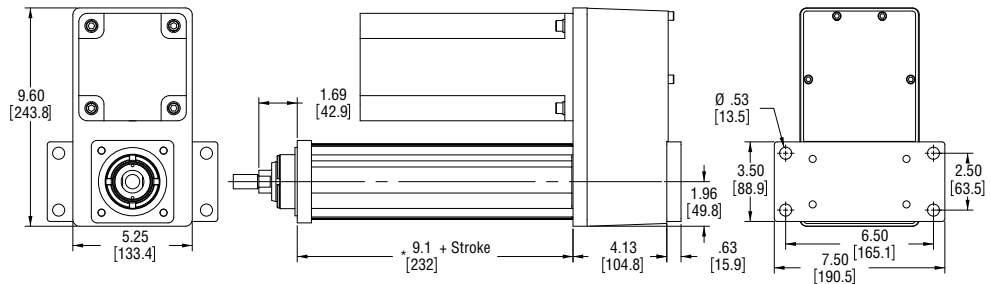

*Add 20mm if choosing high capacity option.

Drawings subject to change. Consult Exlar for certified drawings.

Trunnion Unit

Parallel motor mount shown.

All dimensions shown in inches with millimeters equivalents in brackets.

See rod ends for rod end thread details.

Motor plate and cover dimensions are subject to change depending on the motor selection.

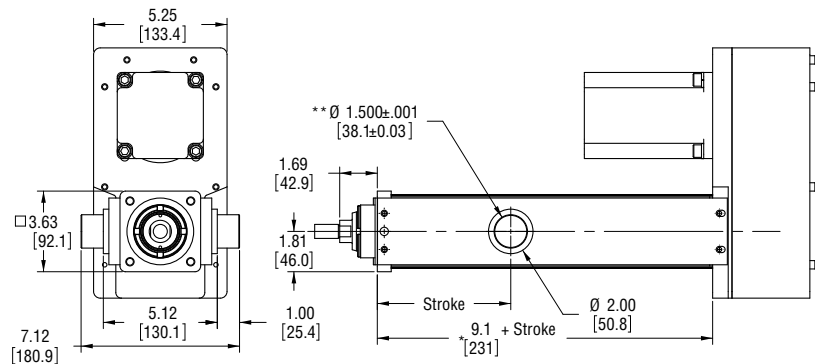

*Add 20mm if choosing high capacity option.
** If "Q" metric side trunnion option, $\text{Ø } 35$ mm h7

Extended Tie Rod Unit

Parallel motor mount shown.

All dimensions shown in inches with millimeters equivalents in brackets.

See rod ends for rod end thread details.

Motor plate and cover dimensions are subject to change depending on the motor selection.

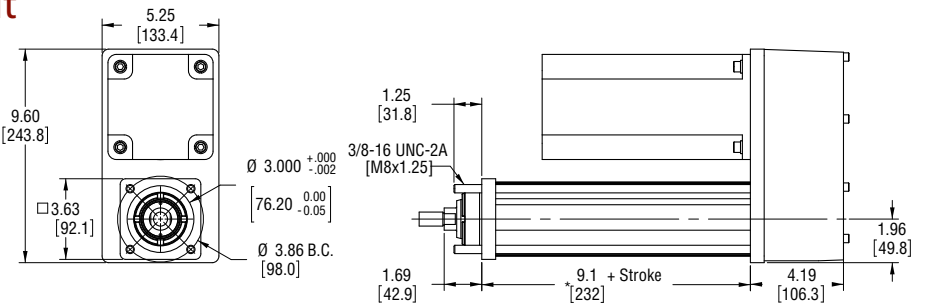

*Add 20mm if choosing high capacity option.

Side Lug Unit

Parallel motor mount shown.

All dimensions shown in inches with millimeters equivalents in brackets.

See rod ends for rod end thread details.

Motor plate and cover dimensions are subject to change depending on the motor selection.

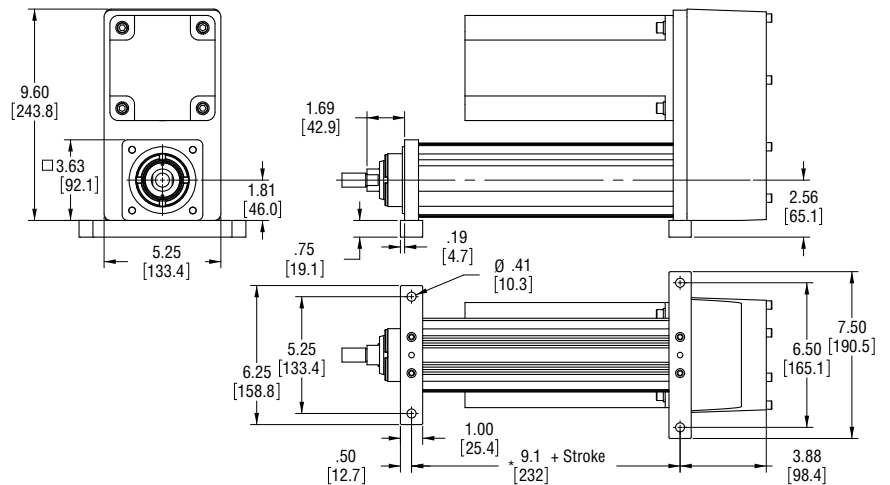

*Add 20mm if choosing high capacity option.

Side Mount Unit

Parallel motor mount shown.

All dimensions shown in inches with millimeters equivalents in brackets.

See rod ends for rod end thread details.

Motor plate and cover dimensions are subject to change depending on the motor selection.

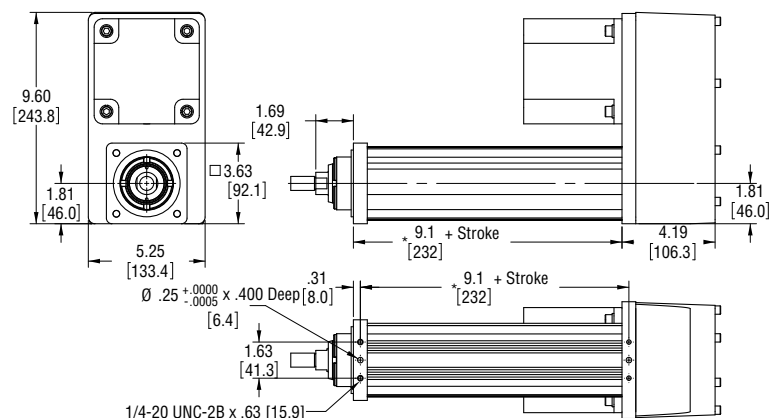

*Add 20mm if choosing high capacity option.

* If "J" or "K" metric side mount options, M6 x 1.0 ∇ 9 mm with $\text{Ø } 6$ mm M7 ∇ 9 mm Dowel Hole

Drawings subject to change. Consult Exlar for certified drawings.

FT60 Series Linear Actuators

Base Unit

All dimensions shown in inches with millimeter equivalent in brackets.

See rod ends for rod end thread details.

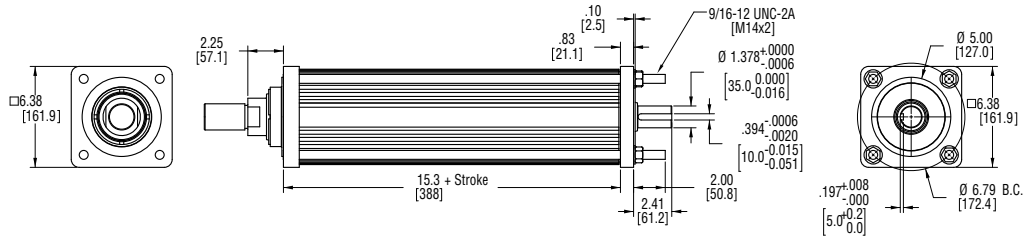

Clevis Mount Unit

Parallel motor mount shown.

All dimensions shown in inches with millimeter equivalent in brackets.

See rod ends for rod end thread details.

Motor plate and cover dimensions are subject to change depending on the motor selection.

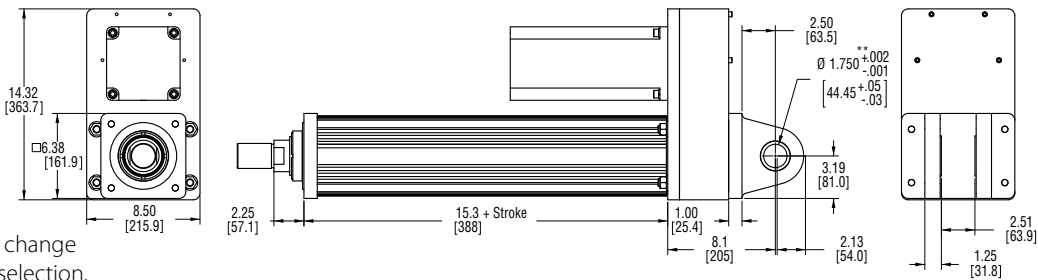

** If "G" metric clevis option, $\varnothing 45 \text{ mm} + 0.00 / - 0.08$

Front Flange Unit

Parallel motor mount shown.

All dimensions shown in inches with millimeter equivalent in brackets.

See rod ends for rod end thread details.

Motor plate and cover dimensions are subject to change depending on the motor selection.

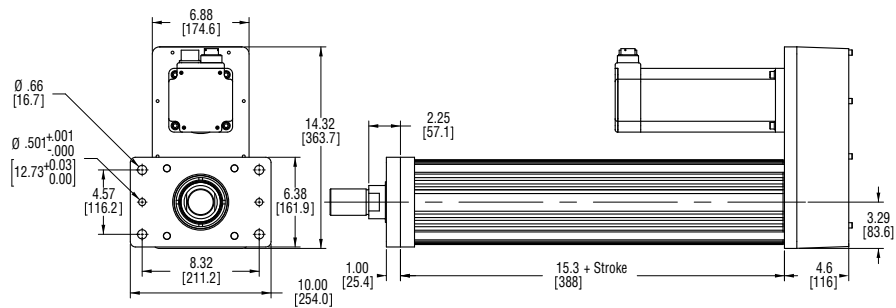

Rear Flange Unit

Parallel motor mount shown.

All dimensions shown in inches with millimeter equivalent in brackets.

See rod ends for rod end thread details.

Motor plate and cover dimensions are subject to change depending on the motor selection.

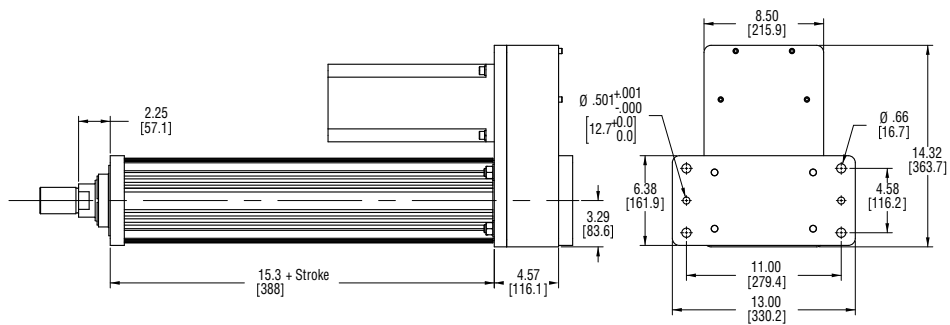

Drawings subject to change. Consult Exlar for certified drawings.

Trunnion Unit

Parallel motor mount shown.

All dimensions shown in inches with millimeters equivalents in brackets.

See rod ends for rod end thread details.

Motor plate and cover dimensions are subject to change depending on the motor selection.

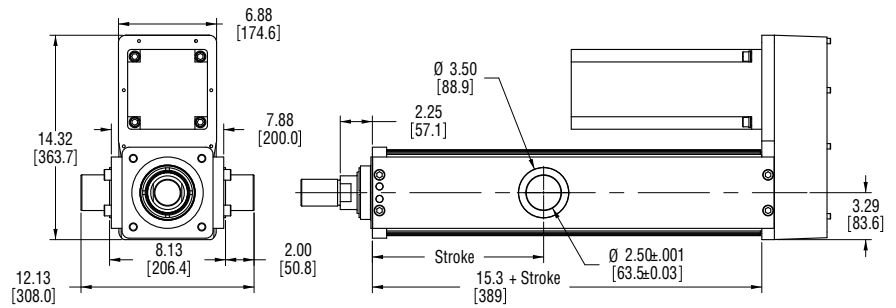

* If "Q" metric side trunnion option, $\varnothing 60$ mm h9

Extended Tie Rod Unit

Parallel motor mount shown.

All dimensions shown in inches with millimeters equivalents in brackets.

See rod ends for rod end thread details.

Motor plate and cover dimensions are subject to change depending on the motor selection.

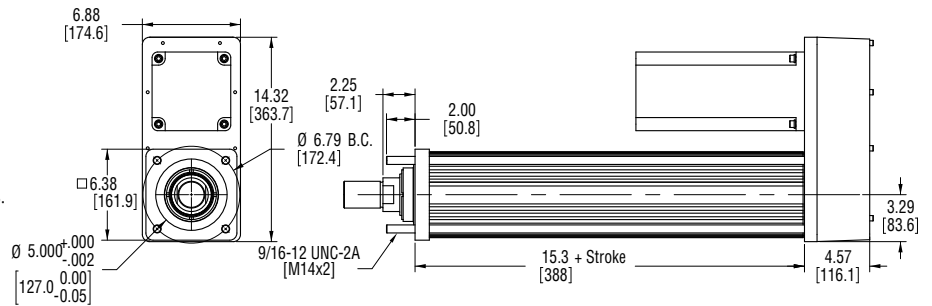

Side Lug Unit

Parallel motor mount shown.

All dimensions shown in inches with millimeters equivalents in brackets.

See rod ends for rod end thread details.

Motor plate and cover dimensions are subject to change depending on the motor selection.

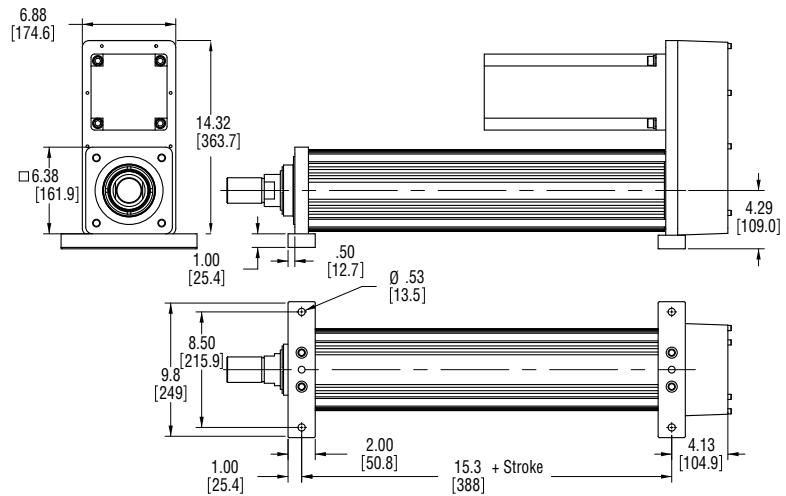

Side Mount Unit

Parallel motor mount shown.

All dimensions shown in inches with millimeters equivalents in brackets.

See rod ends for rod end thread details.

Motor plate and cover dimensions are subject to change depending on the motor selection.

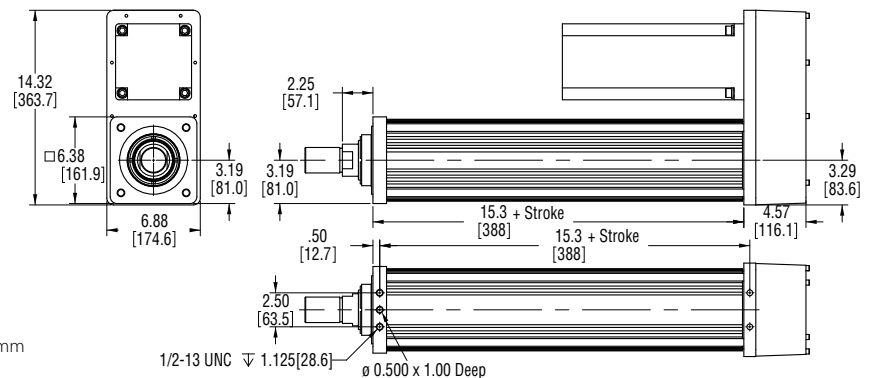

* If "J" or "K" metric side mount options, M12 x 1.75 ∇ 19 mm with $\varnothing 12$ mm M7 ∇ 12 mm Dowel Hole

Drawings subject to change. Consult Exlar for certified drawings.

Base Unit

All dimensions shown in inches with millimeter equivalent in brackets.

See rod ends for rod end thread details.

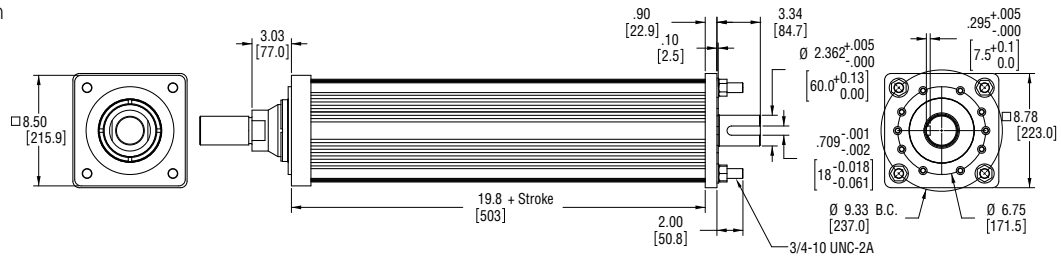

Front Flange Unit

Parallel motor mount shown.

All dimensions shown in inches with millimeter equivalent in brackets.

See rod ends for rod end thread details.

Motor plate and cover dimensions are subject to change depending on the motor selection.

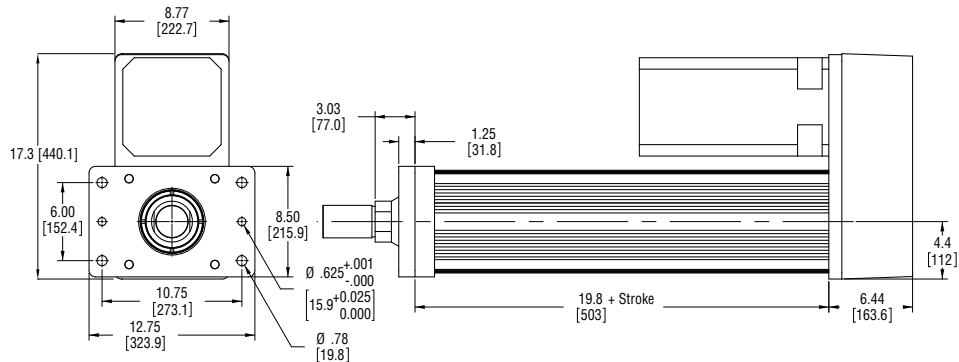

Extended Tie Rod Unit

Parallel motor mount shown.

All dimensions shown in inches with millimeter equivalent in brackets.

See rod ends for rod end thread details.

Motor plate and cover dimensions are subject to change depending on the motor selection.

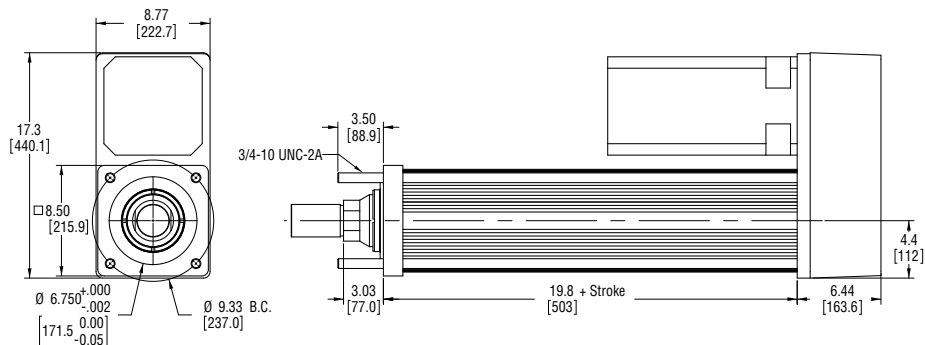

Side Lug Unit

Parallel motor mount shown.

All dimensions shown in inches with millimeters equivalents in brackets.

See rod ends for rod end thread details.

Motor plate and cover dimensions are subject to change depending on the motor selection.

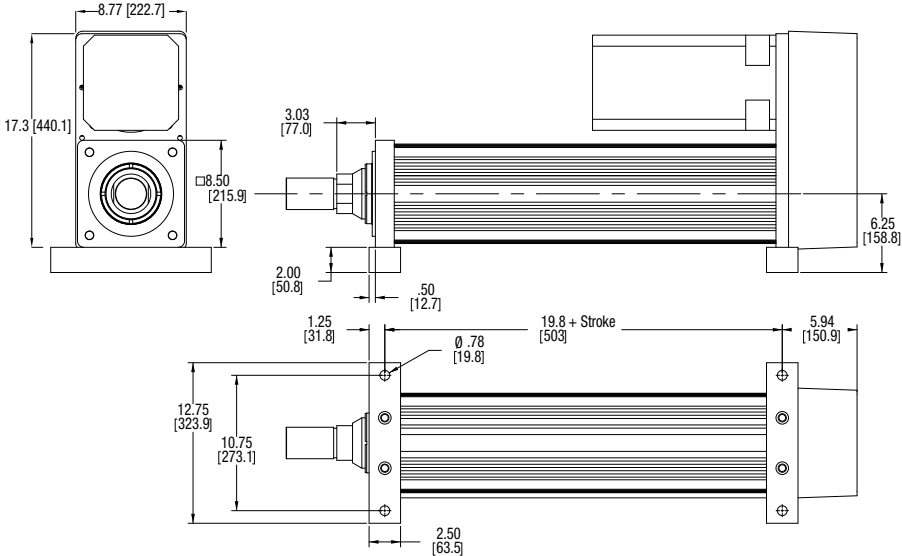

Side Mount Unit

Parallel motor mount shown.

All dimensions shown in inches with millimeters equivalents in brackets.

See rod ends for rod end thread details.

Motor plate and cover dimensions are subject to change depending on the motor selection.

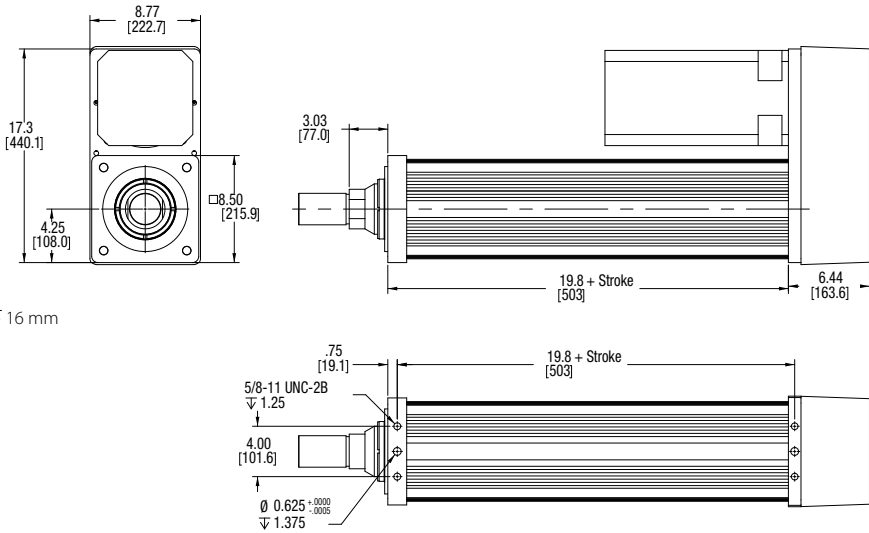

* If "J" or "K" metric side mount options, M16 x 2.0 ∇ 16 mm with \varnothing 12 mm M7 ∇ 12 mm Dowel Hole

NOTE: For Clevis, Trunnion or Rear Flange, Consult Exlar

Rod Ends

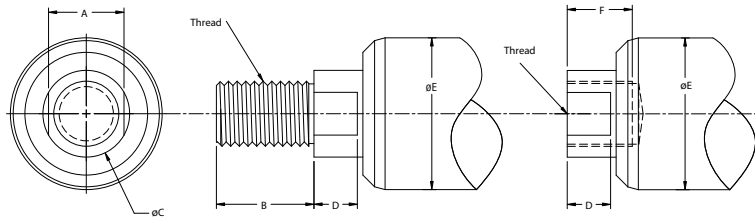

	A in (mm)	B in (mm)	ØC in (mm)	D in (mm)	ØE in (mm)	F in (mm)	Male U.S.	Male Metric	Female U.S.	Female Metric
FT35	0.87 (22.1)	1.125 (28.6)	1.000 (25.4)	0.500 (12.7)	1.750 (44.5)	0.750 (19.1)	3/4-16 UNF-2A	M16x1.5 6g	3/4-16 UNF-2B	M16x1.5 6h
FT60	2.00 (50.8)	2.750 (69.9)	2.360 (59.9)	0.750 (19.1)	3.000 (76.2)	2.000 (50.8)	1 7/8-12 UN-2A	M42x4.5 6g	1 7/8-12 UN-2B	M42x4.5 6h
FT80	2.75 (69.9)	4.019 (102.1)	3.143 (79.8)	1.000 (25.4)	4.000 (101.6)	2.250 (57.2)	2 1/2-12 UN-2A	M56x5.5 6g	2 1/2-12 UN-2B	M56x5.5 6h

NEMA Standard Motor Dimensions

The FT Series actuators offer the selection for motor mounting provisions to be the various NEMA motor sizes. Because there are variations from brand to brand of motor as to what is called NEMA dimensions, we publish this table of NEMA dimensions that we use as the standards for the product line. If the motor that you choose differs from these dimensions, it would not be called out by the N23, N34, N42, N56 call outs, and rather, by the A## alpha numeric callout for specific motors.

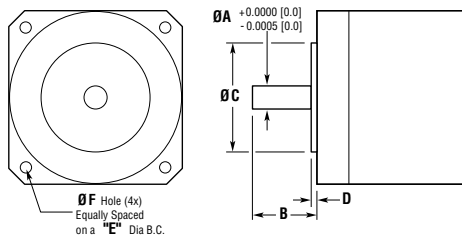

Dimension (in)	NEMA 23	NEMA 34	NEMA 42	NEMA 56
"A" Motor Shaft Diameter	0.25	0.5	0.75	0.625
"B" Motor Shaft Length	0.81	1.19	2.19	2.0625
"C" Motor Pilot Diameter	1.5	2.875	2.186	4.5
"D" Pilot Depth	0.05	0.0625	0.0625	0.1 - 0.16
"E" Mounting Bolt Circle	2.625	3.875	4.95	5.875
"F" Mounting Bolt Hole Dia.	0.205	0.223	0.328	3/8-16 UNC tap

Drawings subject to change. Consult Exlar for certified drawings.

Case Dimensions

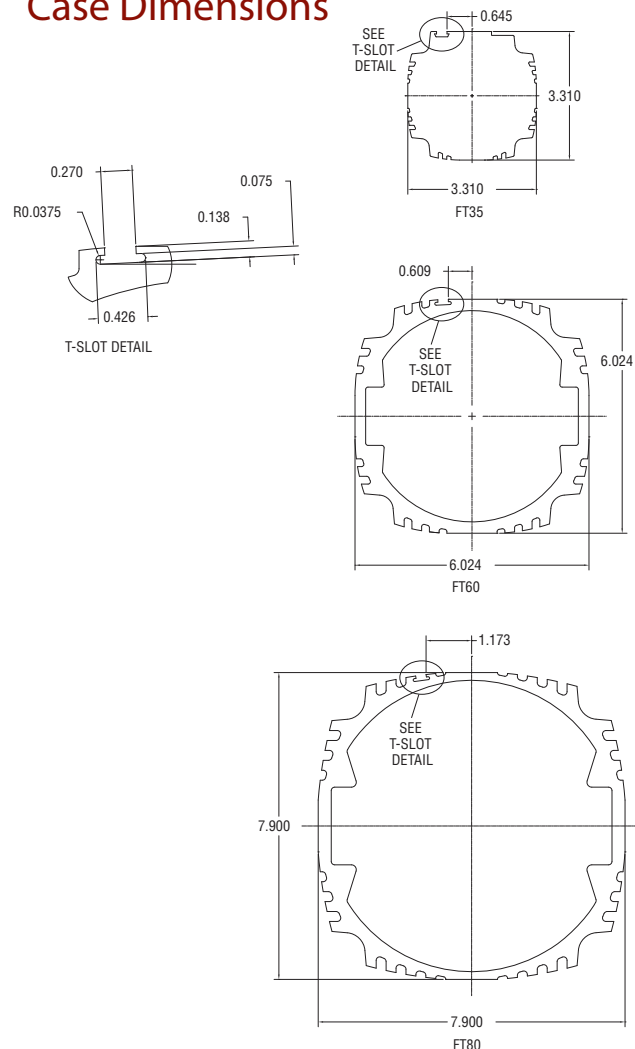

GGG = Motor Mount Provisions ^{3,4}

A## = Alpha numeric motor call out – contact Exlar Applications Engineering Department. Motor not included.
 NMT = No motor mount – keyed shaft on base unit only
 N23 = Nema 23 standard dimension
 N34 = Nema 34 standard dimension
 N42 = Nema 42 standard dimension.
 N56 = Nema 56 standard demension.
 M60 = Exlar 60 mm SLM. Motor not included.
 M90 = Exlar 90 mm SLM. Motor not included.
 M11 = Exlar 115 mm SLM and ER. Motor not included.
 M14 = Exlar 142 mm SLM. Motor not included.
 M18 = Exlar 180 mm SLM. Motor not included.
 G60 = Exlar 60 mm SLG. Motor not included.
 G90 = Exlar 90 mm SLG. Motor not included.
 G11 = Exlar 115 mm SLG and ER. Motor not included.
 AB3, 4, 6, 8 = Allen Bradley Ultra 3, 4, 6 and 8 inch motors

BD3, 4, 6, 8 = Baldor 3, 4, 6 & 8 inch motors
 CM3, 4, 6, 8 = Parker (Custom Servo Motors) Metric 3, 4, 6 & 8 inch motors
 EE3, 4 = Emerson EMC Imperial 3 & 4 inch
 EM3, 4, 6, 8 = Emerson EMC Metric 3, 4, 6 & 8 inch
 FA 4, 6, 8 = Fanuc 4, 6 & 8 inch motors
 IN3, 4, 6, 8 = Bosch-Rexroth (Indramat) 3, 4, 6 and 8 inch motors
 KM2, 4, 6, 8 = Kollmorgen B & M 20, 40, 60 and 80 Series
 MT3, 4, 6, 8 = Mitsubishi 3, 4, 6 & 8 inch motors
 PS3, 4, 6, 8 = Pacific Scientific PMA/PMB Series
 PC2, 3, 4, 6 = Parker Compumotor Apex 2.7, 3.6, 4.5 and 5.6 inch
 SM2 = Siemens 2 inch motor
 SM3 = Siemens 3 inch motor
 YS3, 4, 6, 8 = Yaskawa 3, 4, 6 and 8 inch motors
 MXX = Unlisted or special motor mounting provisions

AA = FT Frame Size

35 = 3.5 inch (90 mm)
 60 = 6.0 inch (150 mm)
 80 = 8.0 inch (200 mm)

BB = Stroke Length

06 = 6 inch (150 mm) FT35
 12 = 12 inch (300 mm) FT35, 60, 80
 18 = 18 inch (450 mm) FT35
 24 = 24 inch (600 mm) FT35, 60, 80
 36 = 36 inch (915 mm) FT35, 60, 80
 48 = 48 inch (1220 mm) FT35, 60, 80

CC = Screw Lead

05 = 0.2 inch, FT35
 06 = 0.23 inch, FT60, 80
 10 = 0.39 inch, FT35
 12 = 0.47 inch, FT60, 80
 20 = 0.79 inch, FT35
 30 = 1.18 inch, FT60, 80

D = Mounting Style¹

L = Side lugs
 B = Front/rear flange (5)
 C = Rear clevis (5)
 F = Front flange
 R = Rear flange (5)
 S = Side mount
 D = Double side mount
 T = Side trunnion mount (5)
 E = Extended tie rods
 J = Metric side mount
 K = Metric double side mount
 Q = Metric side trunnion
 M = Metric extended tie rods
 G = Metric rear clevis (5)
 X = Special (please specify)

E = Moter Mounting Configurations

N = None
 I = Inline direct drive (includes Exlar standard coupling)
 P = Parallel, 1:1 drive
 Q = Parallel, 2:1 reduction
 X = Special

F = Rod End

M = Male, US std. thread
 A = Male, metric thread
 F = Female, US std. thread
 B = Female, metric thread
 W = Male, US std. thread 416C SS, rod end only
 R = Male metric thread 416C SS, rod end only
 V = Female, US std. thread 416C SS, rod end only
 L = Female, metric thread 416C SS, rod end only
 X = Special (please specify)

XX .. XX = Options

Housing Options

XH = Special housing options
 HC = Type III hard coat anodized, class I²
 XT = High capacity roller screw
 SS = Stainless steel²
 FG = Smooth white epoxy²
 (IP65 sealing of unit with motor mounted requires “XH” option.)²

Special Follower

PF = Preloaded follower. The dynamic load rating of zero backlash, preloaded screws is 63% of the dynamic load rating of the standard non-preloaded screws. The calculated travel life of a preloaded screw will be 25% of the calculated travel life of the same size and lead non-preloaded screw for the same application.
 FX = Special follower

End Switches (adjustable position throughout stroke)

L1 = One adjustable switch, (10-30 VDC, PNP, N.C., 1m. 3 wire embedded cable)
 L2 = Two adjustable switches, (10-30 VDC, PNP, N.C., 1m. 3 wire embedded cable)
 L3 = Three adjustable switches, (10-30 VDC, PNP, N.C., 1m. 3 wire embedded cable)

Please provide a drawing of motor dimensions with all orders to insure proper mounting compatibility.

= Part No. Designator for Specials Optional 5 digit assigned part number to designate unique model numbers for specials.

Note:

1. Mounting face size, shaft length and other details of particular motors may require special adapters or provisions for mounting. Always discuss your motor selection with Exlar engineering.
2. These housing options may also indicate the need for special material main rods, faceplate and motor mounting provisions. Internal anti-rotate is not available with stainless steel options. Consult Exlar Applications Engineering.
3. NEMA callout must meet specifications on page 92 or use alpha-numeric callout.
4. MAX Std. motor size FT35: 4 inch/115 mm, FT60 & 80: 8 inch/200 mm. For oversized motors, consult Exlar Applications Engineer.
5. Not available with inline motor mount. Consult Exlar Applications Engineering.