

Gridspace Corporation – 6 DOF Motion Simulator Application

Application Challenge: Gridspace Corporation, a simulation expert in South Korea, required a 6 DOF motion base for a local museum’s 4D theatre where a 3d film is combined with physical effects. (Visit <http://www.gridspace.co.kr>)

Exlar Solution: With Exlar’s all electric actuators, Gridspace achieved the desired results -- servo control for accuracy and repeatability, choice of motor flexibility, precise positioning, and overall long life. The I Series servo-controlled actuators use roller screw technology which allowed Gridspace engineers to design the system to simulate an appropriate motion with repeatability and easy implementation.

Exlar’s roller screw technology was chosen over less capable solutions such as ball screw actuators. Ball screws do not provide the smooth and accurate motion required, nor the long life and stiffness that make simulator applications like this successful.

Exlar Products: I Series actuator (IX30, 12 inch stroke)

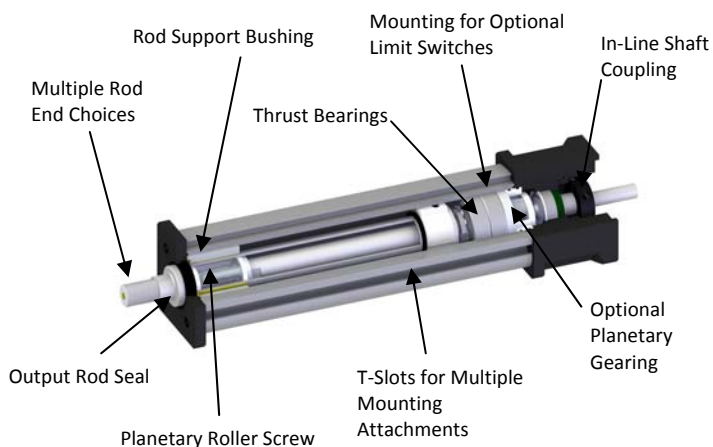

The Exlar Linear Actuator Advantage with Planetary Roller Screw Technology

- Millions of cycles without re-lubrication or maintenance
- Roller screws offer 15 times longer life than ball screws
- Less noise than other motion technologies
- Less energy consumption than fluid power with electric actuation
- Accurate and repeatable positioning
- Wide variety of mounting styles
- High cycle rates
- Multiple stroke lengths

Optimize your application with Exlar actuators. Visit www.exlar.com for complete product information or call us at 952-500-6200. You may also email us at info@exlar.com.