

### Oil Free Hydraulic Replacement

#### Ideal Replacement:

Exlar's linear actuators provide an ideal replacement for hydraulic cylinders typically used for positioning in sawmills.

Whether canter saws or edging saws, the robust design of the GSX and FT Series actuators from Exlar can survive the rugged environment of a sawmill while providing accurate positioning at high rates and with high force. Exlar's linear actuators use planetary roller screw technology to offer many times the load capacity and travel life of ball screws. They also offer higher tolerance to shock load and more stiffness than ball screws.

By eliminating the need for oil, Exlar's electro-mechanical actuators also provide an environmentally friendly solution. Oil leaks and the associated maintenance are a thing of the past. Exlar actuators also provide a more efficient system than hydraulics and offer an electrical energy savings.

#### Exlar Solution:

The hassles of hydraulic cylinder set-up and maintenance are eliminated by using Exlar's all-electric servo based cylinders. Utilizing servo technology, and a completely sealed package, the GSX Series actuators from Exlar can be simply retrofitted for most hydraulic cylinders, cleanly and easily. Cylinder style mounting options are available to choose from, as well as standard cylinder rod end attachments.

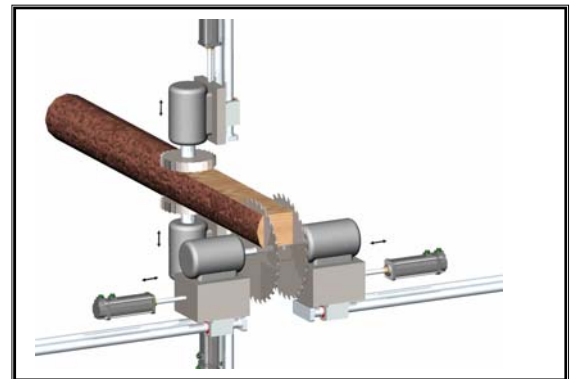

#### Exlar Products:

Exlar GSX Series Linear Actuator with Integrated Servo Motor

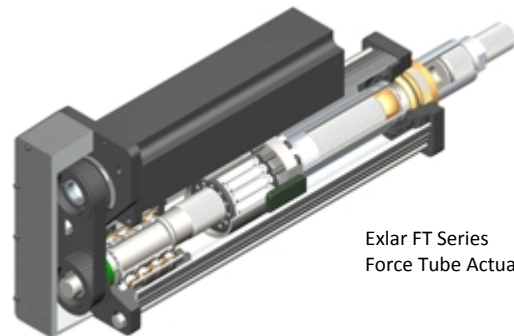
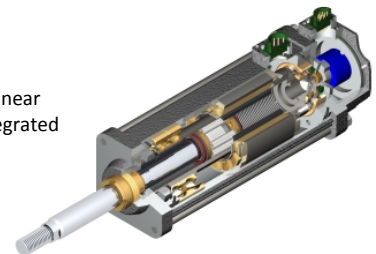

Exlar FT Series Force Tube Actuator

The GSX Series actuators offer peak forces to 25,000 pounds and stroke lengths to 18 inches. The FT Series actuators offer peak forces to 40,000 pounds and stroke lengths to 8 feet. These two series of actuators offer solutions for nearly any linear motion application in a sawmill.

Call us today at 952-500-6200 to learn how you can optimize your application. Visit us at [www.exlar.com](http://www.exlar.com) for complete product information or email us at [info@exlar.com](mailto:info@exlar.com).