

# Exlar's FT Series Actuator Performs in Class II Hazardous Location Environment

## APPLICATION

Coal Diverter Gate

## CUSTOMER

A coal gasification plant that produces natural gas for energy production and captures carbon dioxide for storage. This plant also produces ingredients found in fertilizer and many chemicals used in various different industries such as refrigeration, solvents, and lighting.

## CUSTOMER CHALLENGE

The customer was using an Andco hydraulic actuator to control their coal diverter gate. Due to the actuator's age, the customer was experiencing difficulties sourcing replacement parts for the unit. The Andco actuator also utilized old technology that the customer wanted to update through the purchase of a new actuator solution. This application required an actuator with a long stroke length that could control the motion of their large coal diverter gate. This application also required a solution that was rated for Class II hazardous locations because of the presence of coal dust in the facility.

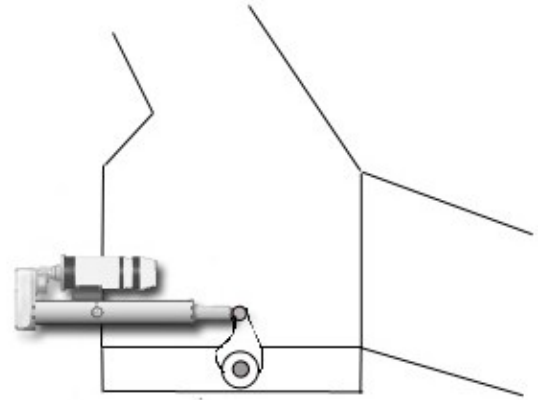

Drawing of Exlar's FT60 actuator installed on the coal diverter gate.

## SOLUTION

The customer had previous experience with Exlar on a turbine application and felt comfortable with the Exlar product. They worked with the local Exlar representative and decided to purchase two FT60 actuators. The actuators provided the necessary stroke length for this challenging application; one actuator with a 12 inch stroke and the other with a 24 inch stroke. Operating in a Class II environment was required for this actuator solution and Exlar's FT60 combined with a Leeson Explosion Proof motor and a Grove gear reducer satisfied this requirement. The customer also required a special trunnion mount and motor support bracket for their application which Exlar willingly designed. This non-standard trunnion mount and custom motor support was easily incorporated on to the FT60 actuator because of Exlar's immense experience designing and manufacturing custom made actuator solutions for their customers.

## RESULTS

- Updated old technology
- Eliminated difficulty of sourcing replacement parts
- Improved performance
- Reduced physical size of actuator assembly

For more information visit our website [www.exlar.com](http://www.exlar.com) or e-mail us at [info@exlar.com](mailto:info@exlar.com)

# EXLAR