

Delivering more accurate and trouble-free test actuators.

Exlar Electric Test and Simulation Actuator Systems

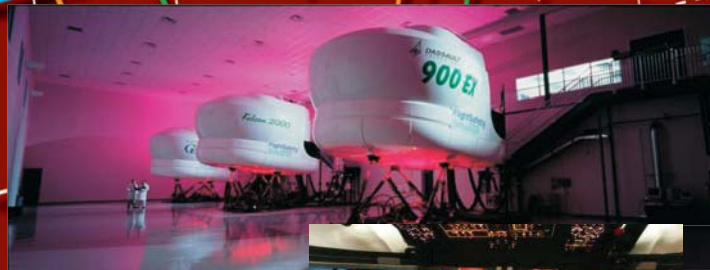
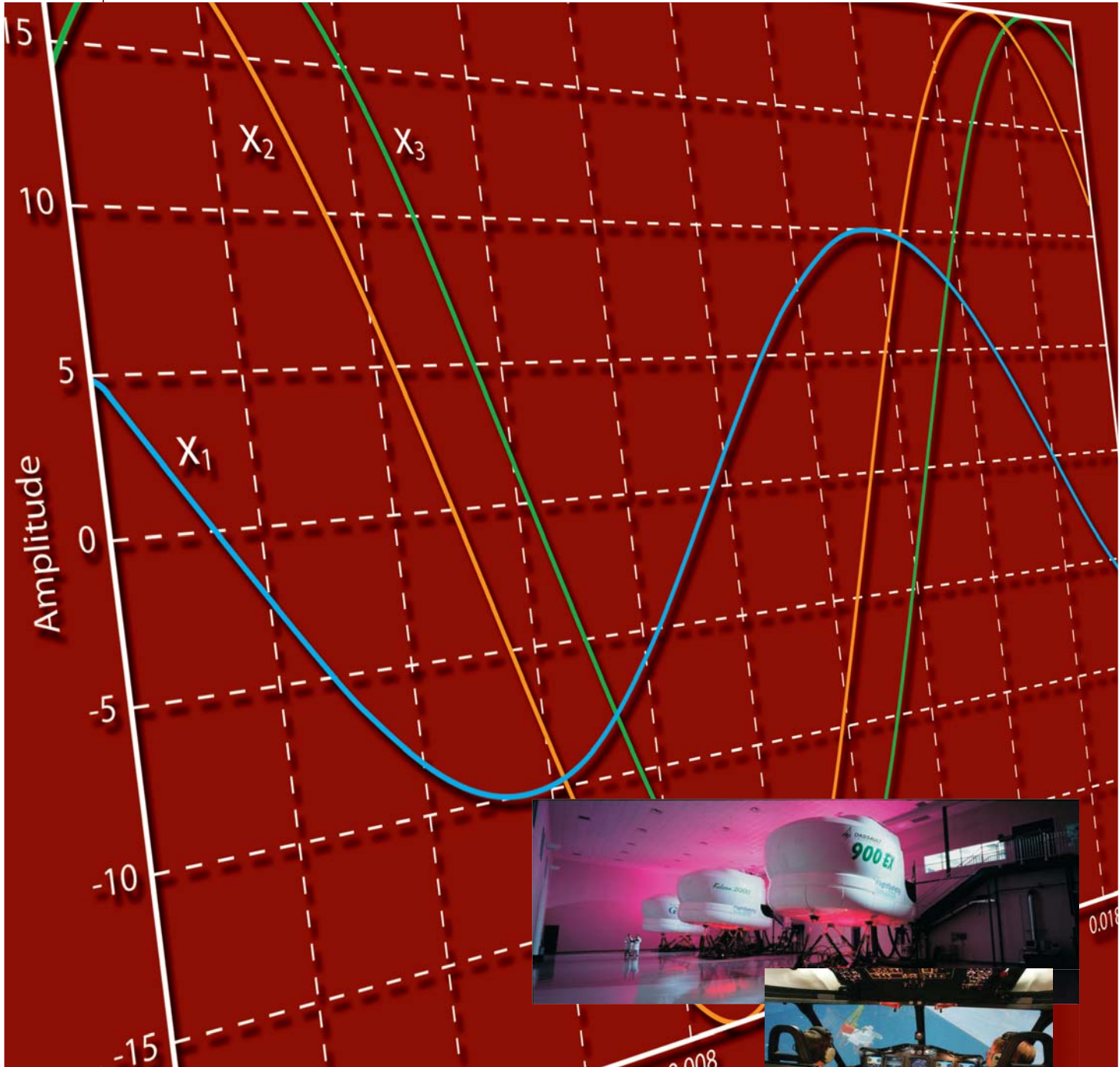

EXLAR

Paradigm Shift in Mechanical Testing System Technology

Historically, manufacturers and users of mechanical test apparatus and motion simulators have accepted the inaccuracies, inconvenience and high maintenance costs of hydraulic actuation. However, today's simulators and test stands are often used in environments where contamination from oil leaks is not permissible and greater accuracy is required. Exlar offers a full range of all-electric test actuators and position controls which provide the dynamic performance and long life required for test and simulation equipment.

entertainment simulators, ergonomic endurance test equipment, geological test equipment, wear testing, and even aircraft structural testing and dynamic simulation.

The Benefits of All-Electric Test Actuator Systems

Exlar's patented roller screw linear actuator technology allows users to perform the analysis and testing needed to verify products' designs without the high cost of installation, constant maintenance, environmental issues, and energy consumption encountered with servo hydraulic systems.

Improved Control

Exlar actuators allow designers of motion simulators and test systems to experience a substantial improvement in control over that achieved using hydraulic systems.



Exlar actuators are directly controlled by the system's electric servo amplifier. No intermediary such as oil or air is required to create motion. System compliance resulting from use of fluid power is a major contributor to inaccuracy of hydraulic actuator systems. The higher stiffness of a planetary

roller screw-based actuator provides greater system response and stability assuring precise and crisp control, and stiffness is not stroke-sensitive.

Speed, Load Ratings and Lifetime

Exlar actuator systems due to their design can operate at speeds of 40 inches per second which is substantially faster than conventional servo hydraulic systems.

Load ratings and lifetime for all-electric systems compete handily with hydraulic systems, providing equivalent, and oftentimes greater performance. Given that an all-electric system requires very minimal maintenance, the load and life factor become distinct advantages over an hydraulic option.



Fifteen years experience in the design, manufacture and implementation of planetary roller screw actuators gives Exlar the edge in applying all-electric actuation for use in applications ranging from motion bases, hexapods,

Reduced Risk of Specimen Damage

System control characteristics are maintained without adjustment or tuning, over widely varying environmental conditions, as calibration does not depend on temperature and contamination sensitive hydraulic valves and fluid mediums. Exlar actuators also maintain a safe position upon the application or removal of power, thus reducing the risk of inadvertent damage to test specimens.

Much Less Infrastructure

Exlar systems require only AC power with easy connection of cables between the servo amplifier and the actuator. No hydraulic power supplies, lines, water cooling or associated facilities are required, often reducing initial cost to a fraction of the cost of a hydraulic system

Space Savings

The space consumed by test system components can be critical to the design of the test cell as well as the space constraints of the facility. Because an electro-mechanical system eliminates the need for the hydraulic power module and system piping, the overall area taken up by the system can be greatly reduced. This space savings can be a key in providing an effective and attractive test or simulation system without the expense of adding or modifying your existing facility.



Reduced Service and Maintenance

Exlar electric actuators eliminate the service and maintenance cost of complex and contaminant-sensitive hydraulic systems. This savings combined with less installed cost means minimal ongoing expense.

Energy Savings

With today's cost of energy, power consumption is an important factor in choosing which technology is employed. Exlar's electromechanical solutions are 80% energy efficient compared to 50% or less for fluid power actuation. This increased efficiency means lower long-term cost.

Reduced Set-up and Reconfiguration Time

Exlar's servo actuators are connectorized in the most convenient manner allowing connection and disconnection with the simple twist of a connector. Once programmed, electric systems generally operate with little or no additional calibration for the duration of its use.

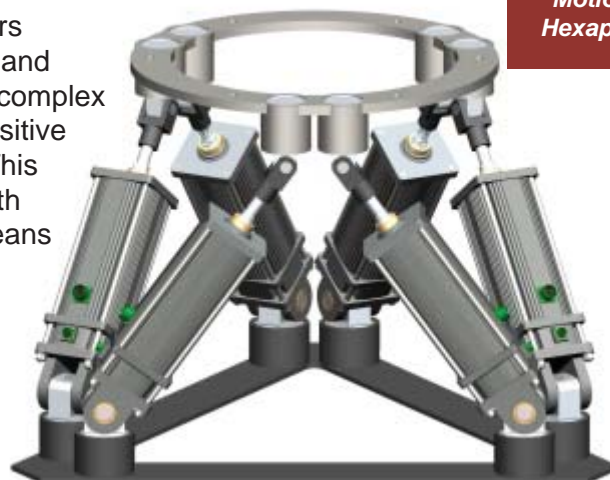

Simply unplug cables by hand (no tools required) and position the actuator in the new location and reconnect to begin operation.

No moving of plumbing, hoses, and accumulators, no recalibration, no bleeding of hydraulic lines, and no clean-up is required. System operation is all digital eliminating drift and allowing continuous storage and recall of set-up and calibration parameters.

Quiet Operation

Electric actuation is very quiet compared to fluid power actuators. The noise level of hydraulic actuators (not including the hydraulic power supply) can reach levels of 85 decibels or more. Exlar actuators operate at high rates of speed and yet maintain decibel levels in the low 70's.

The Challenge

For years, industry has sought out a clean and efficient all-electric alternative to hydraulic and pneumatic cylinders. The promise of such a device would be the elimination of the environmental issues associated with hydraulic fluids, the noise and inconsistency of pneumatics, and a dramatic reduction in power consumption. Today, process engineers are facing increasing demands for more accurate and better responding position control. These trends are driven by regulatory controls for cleanliness and efficiency combined with the market's demand for more accurate control of their processes. Engineers have universally agreed that the solution for addressing both these needs lies in an all-electric actuator. The challenge has been to build such a device which delivers the promises of electric actuation, yet maintains the robustness and moderate cost of fluid power actuators.

The Design — To meet this challenge, Exlar embarked on a mission to create a new kind of electrical actuator. Traditional ball and acme screws were rejected due to their lack of robustness and limited service life when used in continuous motion applications. Direct acting electric actuators were found to be prohibitively expensive, energy inefficient, and lacking the stability and stiffness needed to ensure accuracy. The result of Exlar's

research and creativity is a revolutionary design which incorporates a high performance brushless servo motor with a novel mechanism for converting the motor's power and speed to highly accurate and reliable linear motion.

The Result — Since delivering the first actuator to the world's leading liquid packaging company in 1993, the company has supplied over 10,000 units of this elegant but simple device for producing precise, yet highly robust linear motion. Exlar's inverted roller screw actuators are being used today

on industrial equipment ranging from carpet weaving machines and machine tools, to simulation and test equipment and submarines. All actuators portray the unique characteristics of producing the power density, speed and robustness of hydraulic and pneumatic actuation without the inconvenience and operating expense of fluid power.

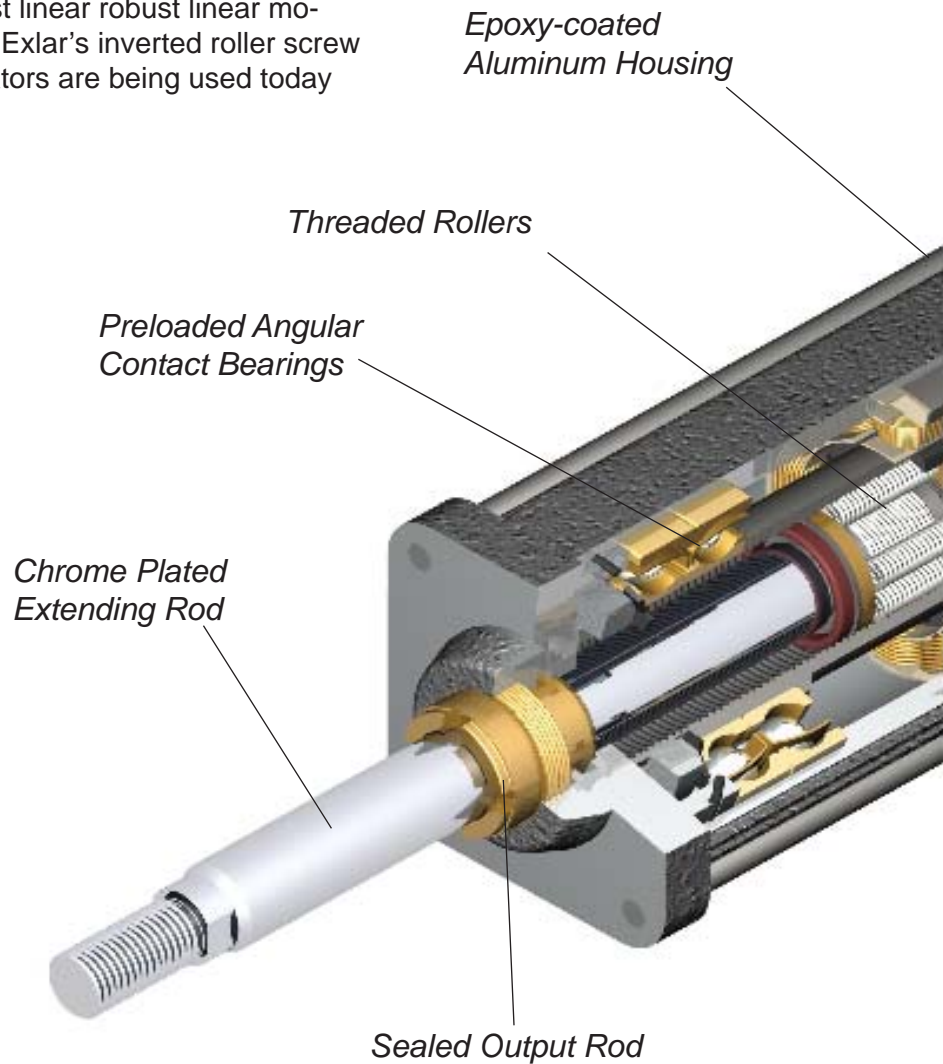

The Solution

The Operation -- Exlar's patented linear actuator is based on a unique design for integrating a robust and efficient threaded roller mechanism into the interior of a high power density, high performance brushless servo motor. This combination results in an

MS Style Connectors Std.

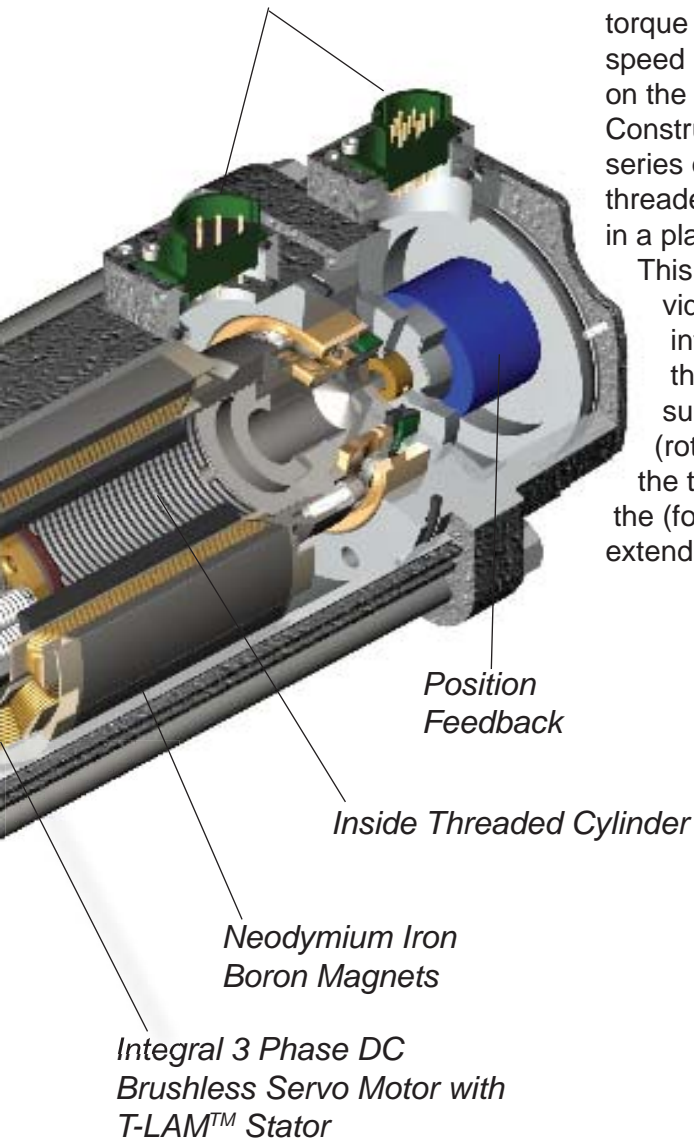

all-electric actuator which is extremely compact, yet delivers similar performance to a hydraulic cylinder in terms of force, robustness to shock and long service life.

In response to current flow, the servo motor produces torque and power in rotation. The internal roller screw mechanism converts the rotational motion and torque to a high force, high speed linear output to act on the applied load. Construction includes a series of load-bearing, threaded rollers assembled in a planetary arrangement. This assembly provides the mechanical interface between the threaded inside surface of the hollow (rotating) cylinder and the threaded surface of the (force-generating) extending rod.

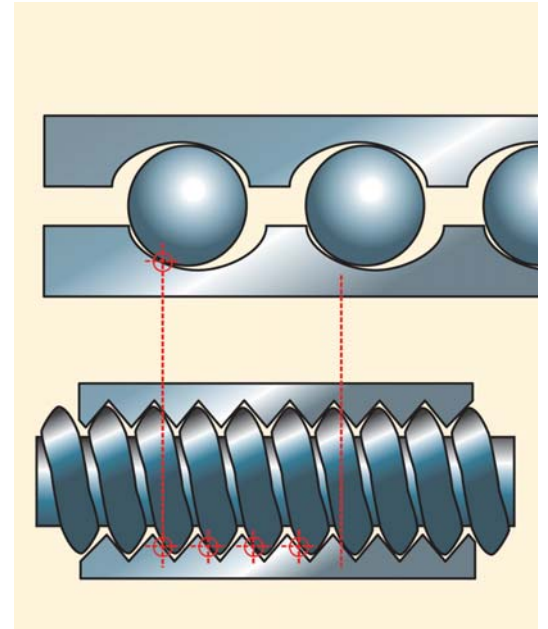

The greater number of contact points in a roller screw compared to a ball screw (above) gives roller screws a longer life, higher load capacity and greater stiffness.

The threaded surfaces of the rollers are of a matched helix configuration and precision machined to contact the rotating cylinder and follower at many points concurrently. The large number of mechanical interfaces (typically in excess of 100) combine with their shape to create a total contact surface area much greater than that found in a comparable sized ball screw mechanism. This unique design provides dynamic life and shock resistance which is typically 15 times greater than ballscrew mechanisms with similar dimensions.

Successful Applications in Test and Simulation



Entertainment/Animatronics

The compact packages offered in the Exlar product line make for perfect animatronic solutions. Excellent controllability and high force density have made Exlar the preferred choice for some of the world's largest theme parks and movie studios.



Road Simulation

Road simulators for automobiles, motorcycles, trucks and SUVs require an actuator that not only provides aggressive motion capabilities and high thrust loads, but also offers long life, little maintenance and precise data feedback. Exlar's electro-mechanical actuators provide all of these features eliminating the common problems with hydraulic systems such as inconsistent force and position control, cumbersome set up, and difficult tuning and temperature compensation. The high stiffness of Exlar's actuators provide



accurate feedback of position, acceleration and velocity information, and with optional integral load cells, can also offer very accurate feedback of true loading.

accurate feedback of position, acceleration and velocity information, and with optional integral load cells, can also offer very accurate feedback of true loading.

Aircraft Structural Testing

Exlar actuators are ideal for use in aircraft structural dynamic testing as well as satellite and space vehicle testing.



Exlar actuators and controls do not cross couple or operate in an uncontrolled manner during power up, shutdown or emergency stop conditions. They are available with locking, back driving and an internal brake (activated on power fail). This avoids the need for sophisticated load abort manifolds and complex shutdown electronics and greatly reduces the risk of an errant system operation resulting in a damaged specimen.

Hazardous Environments

For lab safety, Exlar electric actuators can be built for work in a hazardous environment. Testing that involves fuel, hot exhaust, and engine operation will benefit from actuators that do not require a flammable hydraulic fluid. Furthermore, Exlar actuators can be provided with a Class I, Div 1 explosion proof rating.



Wave Simulation

The high force capability and static control combined with an oil-free environment makes the Exlar system a perfect choice for wave generation applications. Exlar actuators are available in strokes up to eight feet in length, can provide 80 inch per second velocity, and 40,000 pound force. Case material is aluminum with epoxy paint and options include various grades of stainless steel. Sealing is standard IP54 or IP65.



Clean Room

Exlar actuators are ideal for clean room or even vacuum chambers, in semiconductors and biomedical as they do not use hydraulic fluid and can even be operated without lubricants.



Strength Testing

The small package size, high force density, high rigidity and the ability to offer equal compressive and tensile force output make



Exlar Actuators ideal for incorporation into strength testing

equipment. High actuator rigidity offers the machine builder

the ease of set up and tuning not available when dealing with compressible hydraulic fluid. Position and force measurements are attainable with ease from the electro-mechanical system offering flexible data gathering solutions.

Man Rated Simulators

Simulators designed for use by people have a unique set of requirements well suited to using Exlar's all electro-mechanical servo actuators. The obvious benefit is the elimination of oil in systems that are often used indoors in environments that can not tolerate oil leaks. Hydraulic systems generally have stored energy in the form of column compliance and sometimes nitrogen charged accumulators. Hydraulic actuators can also create decelerations far beyond the acceptable range for human use when the payload is stopped rapidly by an errant valve closure.



Exlar's all electro-mechanical servo actuators. The obvious benefit is the elimination of oil in systems that are often used indoors in environments that can not tolerate oil leaks.



Mechanical Assembly Testing with Load Feedback

Exlar actuators are used to test steering wheel assemblies. The actuators compress two splined parts held apart by an internal spring. Every test cycle includes a force measurement made by a load cell embedded in the actuator (standard option) to determine if the part meets the specified motion/force profile.

Small Size Actuators

Exlar actuators do not have break-out friction issues or oil column instabilities, even for the smallest actuator. Often used in injection molding machines for plastic parts, you get the same control stability and fidelity whether you're using two inch frame or unique sizes.



Often used in injection molding machines for plastic parts, you get the same control stability and fidelity whether you're using two inch frame or unique sizes.

Quality Assurance Testing

Exlar actuators provide verification that production parts are meeting their rated specifications. Several E-Test Actuators are currently in use by one of the world's largest manufacturers of thrust bearings verifying the static load ratings of their bearings in production.



Flight Simulation

Leading simulator manufacturers like Flight Safety International and L3 rely on Exlar actuators to provide smooth and realistic controls resistance for their flight and vehicle simulators. The smoothness of Exlar's roller screw actuators and T-Lam motor technology, combined with robust designs, 100% duty cycle capability, and long life make Exlar the perfect choice for electro-mechanical simulation solutions.



Wear/Life Testing

Exlar actuators are well suited to act as wear and life testing devices for components or equipment. Exlar actuators are currently in use performing life testing of automotive brake systems, earth moving equipment controls and even life testing of ball screws! The long life of the Exlar actuator's planetary roller screw fills the application requirements of life testing applications even at high loads and high cycle rates.



Wind Tunnel

MTS Systems Corporation utilizes Exlar's GSX60 actuators as the legs of an inverted six-degree-of freedom hexapod. These hexapods manipulate the position of 50% and 60% scale Formula 1 models in wind tunnels for the research and development purposes of the race car design teams.



The systems require the precise control of roll, pitch and heave within the wind tunnel to provide the accuracy and repeatability of positioning that the designers require. The form factor, precise control, and high rigidity of the Exlar GSX60 actuators provide MTS Systems Corp with the linear motion solution that they require for this demanding application.

Exlar Features and Options Provide Complete Alternative to Servo Hydraulic Test Systems

data normally required during test operation. The system accepts both analog and digital commands. Analog is either 0-10V or 4-20 mA and can be set up to control position, velocity or force. Multiple forms of position feedback are available including incremental and absolute encoders, resolvers, LVDT or magnetorestrictive linear sensors. An integral force sensor can provide accurate real-time force measurement while motion is generated.

GSX Series Compact Electric Test Actuators

With form factors similar to hydraulic cylinders, Exlar's linear actuators provide a compact, integrated motor and actuator in frame sizes from 2 inches (50mm) to 18 inches (200mm) and force outputs of 580 pounds (2570 N) to 40,000 pounds (200kN). Exlar actuators are ideal when used in applications where cyclic frequency up to 10 Hz and strokes are from 0.1 to 10 feet. Exlar's linear actuators are dimensionally similar to fluid power actuators with standard NFPA front and rear clevis mounts which allow, in many applications, direct substitution for existing equipment.

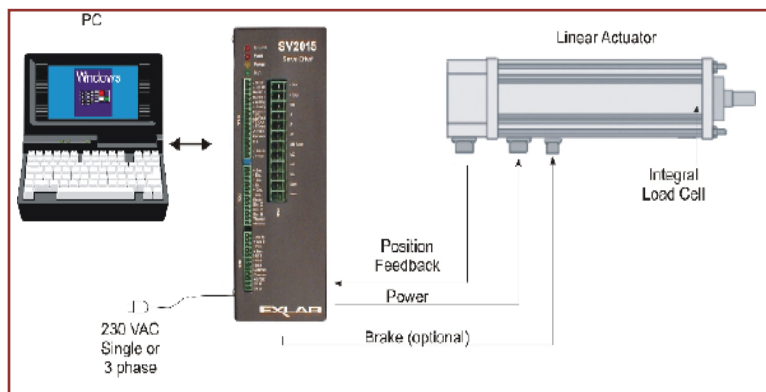

The same servo amplifier used for Exlar's linear actuators can be used with Exlar's rotary actuators.

Exlar's technology is unmatched by any other electro-mechanical device due to its patented integrated roller screw actuator. Additional features such as integral linear position and force sensors provide test engineers with reliable, dynamic data. Precise feedback of key operating parameters assure precise control and event recording.

Closed-Loop Electric Actuator Servo System

Exlar in most cases offers a complete system which includes actuators, amplifiers, and cables. This allows the user to procure electronics that are designed specifically for use in testing applications and operate together. Systems are fully engineered to provide optimized performance, trouble-free long life and the

with the exception of magnetorestrictive LVDT position feedback and integrated load cell. Exlar amplifiers can be interchanged easily as requirements vary from test to test.

Standard mounting configurations include trunnion and face and flange mounts, rear clevis, foot and side mounts. Custom mounts configured to meet your exact needs can be designed and built.

GSX Series Specifications

Size	Nominal Frame Size in (mm)	Max. Stroke Available in (mm)	Rated Force Lbf (N)	Max. Speed in/sec (mm/sec)	L10 Life at Rated Load in x 10 ⁶ (mm x 10 ⁶)
GSX20	2 (50)	12 (300)	578 (2571)	33 (.8k)	228.6 (5806)
GSX30	3 (75)	18 (450)	1347 (5992)	25 (.6k)	508 (12903)
GSX40	4 (100)	18 (450)	3966 (17642)	37.5 (.9k)	76.2 (1935)
GSX50	5 (130)	18 (450)	8544 (38006)	40 (1k)	38.1 (968)
GSX60	7 (180)	12 (250)	12389 (55109)	40 (1k)	57.15 (1452)

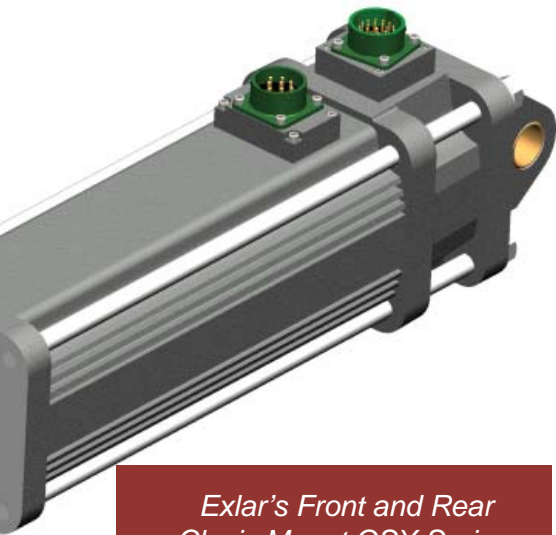

Exlar's Front and Rear Clevis Mount GSX Series Actuator

Standard Features

- Linear speed range to 25 in/sec (635 mm/sec)
- Force rating range to 12,389 pounds/force (55,109N)
- Stroke length range 3 -18 inches (75 - 450 mm)
- Typical life exceeding hundreds of millions of full-stroke operations
- Backlash < .004 in (.1mm)
- IP65 rating

Optional Features

- Handwheel
- Incremental or absolute rotary feedback
- LVDT or magnetostrictive linear sensors
- Embedded force sensor
- Air or liquid cooling
- Special output shaft and mounting
- Preloaded zero backlash
- Stainless steel housing

FT Series Long Stroke Actuators

The FT Series actuators are suited to operate where longer strokes and higher thrusts are

required. The FT Series product offering consists of a roller screw thrust unit and a conventional NEMA or metric frame motor sized to deliver the force and speed needed to accomplish the application.

FT Series Features

- Stroke lengths up to 8 feet (150 mm to 2.5 m)
- Force rating up to 20,000 lbs (88,964 N) continuous, 40,000 lbs (177,929 N) peak
- Speed range up to 60 in/sec (1,524 mm/sec)
- Multiple motor mounting options
- Planetary roller screw drive
- Long life and high load capacity
- Shock resistance

Ft Series force tube actuators use a planetary roller screw mounted inside a telescoping tube mechanism. The follower is attached to the moveable force tube, which then extends and retracts as the screw rotates.

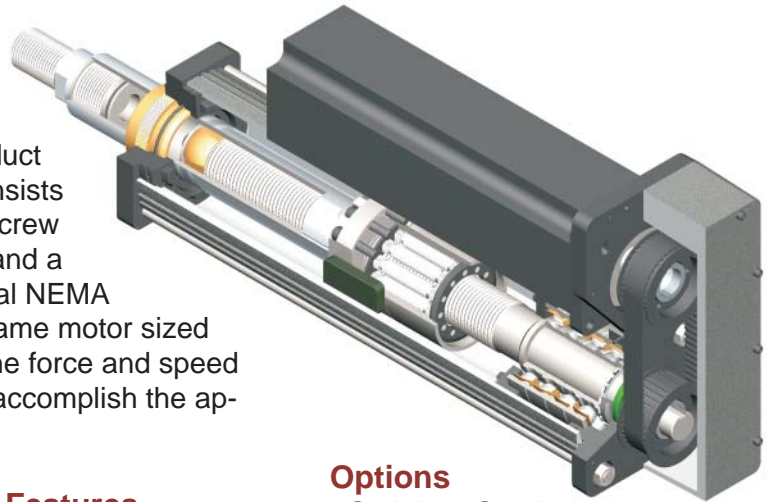

Options

- Stainless Steel
- Special Mountings
- Vacuum
- Dust Free
- Oil or Air Cooling
- Uninterruptable Power
- IP65 sealing

Custom Actuation

Exlar specializes in custom actuators where certain materials and features are incorporated which meet the exact specification of unique testing or simulation applications.

FT Series Specifications

Size	Frame Size in (mm)	Gear Motor (optional)	Maximum Stroke in (mm)	Max. Cont Force lbf (kN)	Peak Force lbf (kN)	Maximum Speed in/sec (mm/sec)
FT35	3.5 (89)	SLG060	48 (1219)	2000 (8.9)	4000 (17.8)	60 (1524)
FT60	6.0 (152)	SLG090	96 (2438)	10000 (45.4)	20000 (90.8)	39 (991)
FT80	8.0 (203)	SLG115	96 (2438)	20000 (90.8)	40000 (178)	35 (889)

Exlar SLG Series Rotary Actuators

Rotary actuators are also provided by Exlar, which, in most cases offer an ideal solution for testing and simulation applications

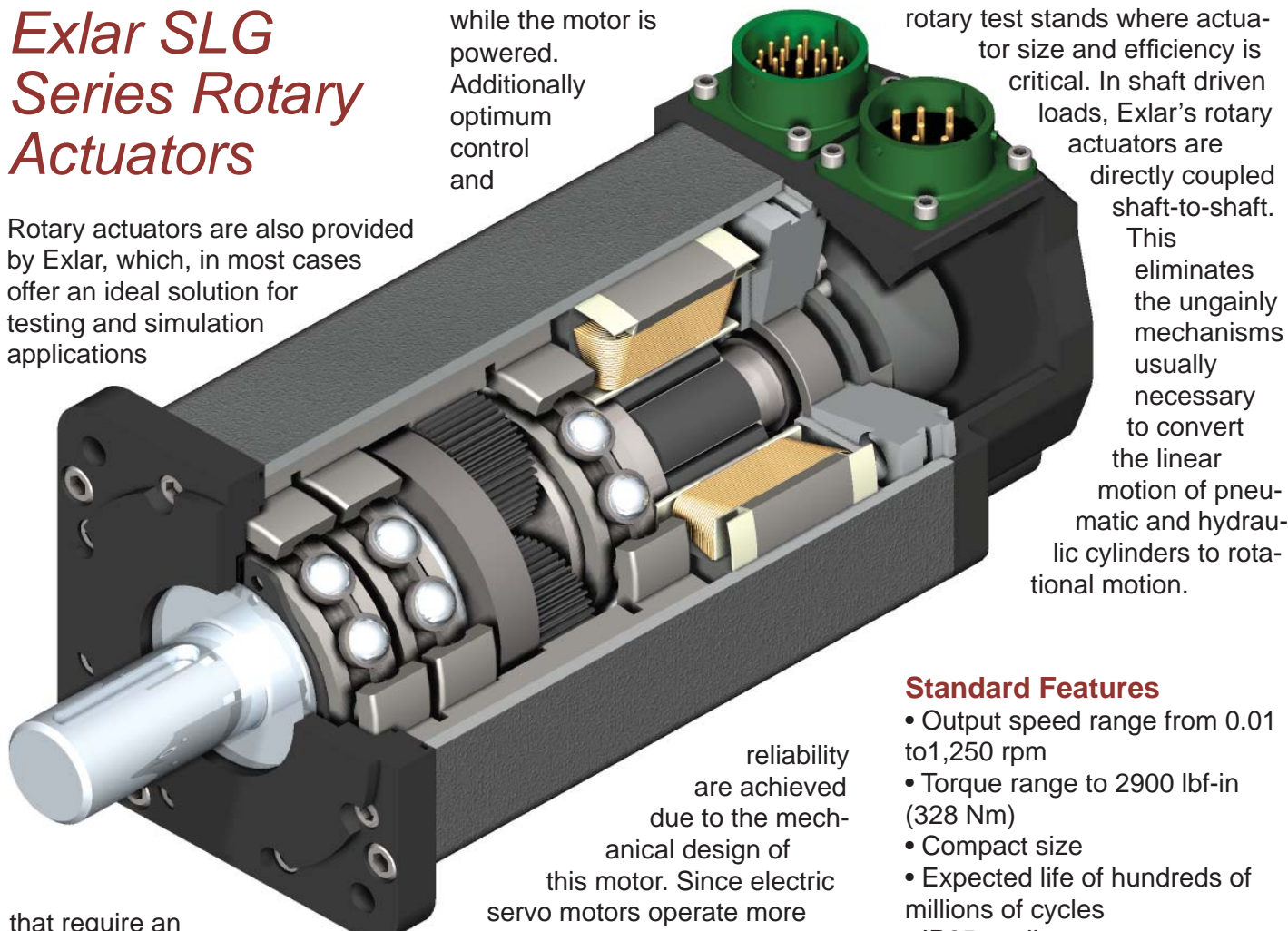

while the motor is powered. Additionally optimum control and

rotary test stands where actuator size and efficiency is critical. In shaft driven loads, Exlar's rotary actuators are directly coupled shaft-to-shaft. This eliminates the ungainly mechanisms usually necessary to convert the linear motion of pneumatic and hydraulic cylinders to rotational motion.

that require an applied torque, rather than an applied linear force. Exlar's rotary actuators include a high power density, electrically operated brushless servo motor closely coupled to a high strength planetary gear reduction mechanism. This acts to multiply the output load capacity of the motor and to assure rigidity in position

reliability are achieved due to the mechanical design of this motor. Since electric servo motors operate more efficiently at moderate velocities rather than low speeds, the planetary gear reducer allows the actuator to operate at efficiencies typically greater than 80%. Three different sizes of rotary actuators allow the test system designer to match the right actuator with each specific application encountered. Exlar's closed-loop, servo controlled rotary actuators are ideal for

Standard Features

- Output speed range from 0.01 to 1,250 rpm
- Torque range to 2900 lbf-in (328 Nm)
- Compact size
- Expected life of hundreds of millions of cycles
- IP65 sealing

Optional Features

- Handwheel
- Incremental or absolute rotary feedback
- Stainless steel housing
- Explosion proof Class I, div 1, Group B, C and D
- Custom shaft and mounting

SLG Series Specifications

Size	Nominal Frame Size in (mm)	Max. Output Torque lbf (Nm)	Maximum Backlash	Output Speed (rpm)
SLG060	2 (50)	340 (38)	10 arc min	1250
SLG090	3 (75)	1550 (175)	10 arc min	1000
SLG115	4 (100)	2900 (328)	10 arc min	750

SV Series Digital Positioner

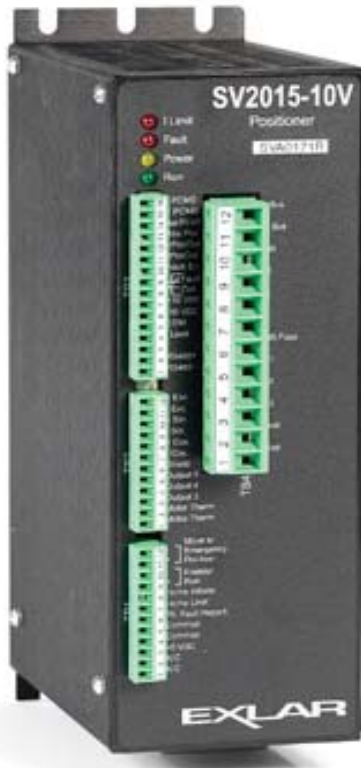

Exlar's SV Series Positioner was designed for use with Exlar rotary and linear actuators in test and simulation systems. The setup and operation is tailored to make its operation functional and easy to use with a 0 to 10, -10 to +10, or 4-20 mA analog position, velocity or force (torque) command signal. The amplifier then generates the pulse width modulated electric power for the actuator to produce the motion in accordance with your command signal. The system is completely closed loop to assure replication of the intended motion. It also allows optimization of the control through the proper setting of the loop gains and amplitude.

The SV2000 provides an analog output in the form of 0-10 Volt or

4-20 mA output which represents the actual position of the actuator on a real time basis. Four sizes of the SV Series Positioner allow you to efficiently match the desired force and velocity (frequency) performance needed in your application.

SV Control Features

- Linear or rotary actuator control
- Position control proportional to analog or digital commands (Modbus)
- Analog or digital output proportional to actual position
- 24 Volt digital inputs and outputs
- ASCII or Modbus protocol serial communication
- Auxiliary analog control capability

Optional Features

- Absolute positioning (with optional absolute sensor)

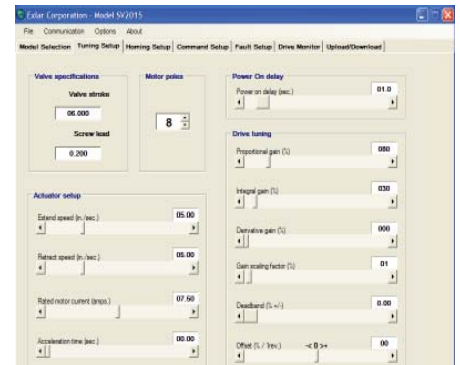

SV Series Specifications

Analog Inputs

Position Command or Sensor Signal: 12 bit (4096 increments) over range of 4-20mA, 0 to 10 VDC or +10 VDC

Absolute Feedback: 12 bit (4096 increments) over range of 0-5 VDC

Auxilliary: Set Point Control, 12 bit (4096 increments) over 0 to 10 or + 10 VDC

Analog Output

Current Position: 12 bit (4096 increments) over 0-20mA

Digital Inputs: Enable operation, Go/To Emergency Position, Fault Reset, Home Limit, Home Initiate, Motor Thermal Switch.

Digital Outputs: Programmable Warnings, Fault

Serial Port: RS485 Standard; RS232 with Converter Box (available from Exlar) ASCII and Modbus protocol.

Resolution of Control: 12 bit (4096 increments) per motor revolution times the pitch of lead (turns of the lead per inch of increment) for linear actuators or times the gear reduction ratio for rotary motion.

Environmental Rating: NEMA 1

Output Rating

	Current				
	RMS	Peak	Power	Voltage In	
	Amps	Amps	Watts	VDC	VAC
SV2008	8	15	2 kW	--	71-240, 3 phase
	7	15	2 kW	100-350	71-240, 1 phase
SV2008-24	8	15	2 kW	20-50	--
SV2015	15	30	2.5 kW	100-350	71-240, 3 phase
	7	30	2.5 kW	--	71-240, 1 phase
SV2015-24	15	30	2.5 kW	20-50	--
SV2035	35	70	6 kW	100-350	71-240, 3 phase
	20	70	6 kW	--	71-240, 1 phase
SV4008	10	15	3 kW	250-760	180-540 3 phase only
SV4020	20	30	7 kW	250-760	180-540 3 phase only
SV4050	50	50	18 kW	250-760	180-540 3 phase only



The Company -- Headquartered in suburban Minneapolis, Minnesota, Exlar serves a global customer base with an extensive standard product line and complete engineering support for custom actuator applications.

Exlar supports a large network of sales representatives in North America. To find your local dealer, visit our website at www.exlar.com or call our headquarters at 952-500-6200.

EXLAR

18400 West 77th Street
Chanhassen, MN 55317
952-500-6200
Toll Free 855-620-6200
Fax 952-368-4877