

EL Series Explosion Proof Linear Actuators

The EL Series linear actuators offer users all of the advantages of Exlar's patented inverted roller screw actuator designs in a Class I, div 1, Groups B, C or D* explosion-proof package. These electro-mechanical systems provide process engineers a clean, fast, simple and cost effective replacement for hydraulic actuation and a longer life alternative to pneumatic actuation. The roller screw technology manufactured by Exlar outperforms rival ball screws by 15 times in travel life, and can carry higher loads. The compact design allows users to effectively replace hydraulic or air cylinders with an electromechanical actuator, yet meet all required capabilities of the application.

The EL Series actuator is compatible with nearly any manufacturers' resolver-based amplifier.

* "Class I" means that flammable gases or vapors may be present in the air in quantities sufficient to produce explosive or ignitable mixtures. "Division 1" means that hazardous concentrations in the air may exist continuously, intermittently, or periodically under normal operating conditions. "Group B" allows for atmospheres containing hydrogen, or gases (or vapors) of equivalent hazard, such as manufactured gas. "Group C" allows for atmospheres containing ethyl-ether vapors,

ethylene or cyclo propane. "Group D" allows for atmospheres containing gasoline, hexane, naphtha, benzene, butane, alcohol, acetone, benzol, lacquer solvent vapors or natural gas. EL Series actuators are not rated for operation in atmospheres containing acetylene.



**EL30
Explosion-Proof
Linear Actuator**
Class I, div 1, Groups B, C and D

Features

T-LAM technology yielding 35% increase in continuous motor torque over traditional windings

Resolver feedback

8 pole motors

Rod end options

1, 2, or 3 stack motor compatible with nearly any servo amplifier

Several mounting configurations

Potted NPT connectors

Windings available from 24 VDC to 460 VAC rms

Class 180H insulation system

TYPICAL APPLICATIONS FOR EL SERIES EXPLOSION-PROOF MOTORS ARE WELL-SUITED TO MANY APPLICATIONS SUCH AS:

Turbine fuel flow

Printing presses

Engine test stands

Fuel distribution systems

Chemical process plants

Shipbound fuel management

EL Series Performance Curves

The below speed vs. force curves represent approximate continuous thrust ratings at indicated linear speed. Different types of servo amplifiers will offer varying motor torque and thus actuator thrust. These values are at constant velocity and do not account for motor torque required for acceleration.

EL30-.2 Inch Lead

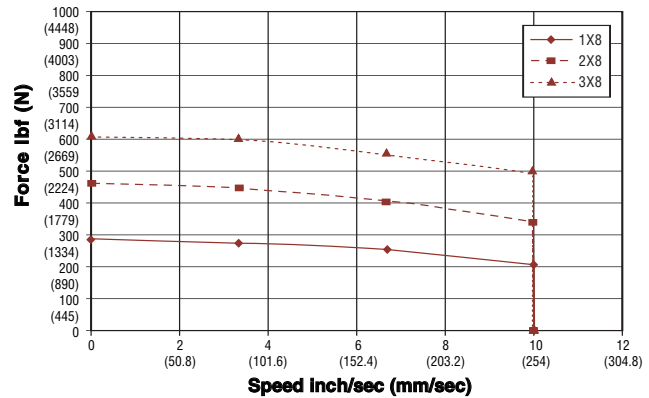

EL30-.1 Inch Lead

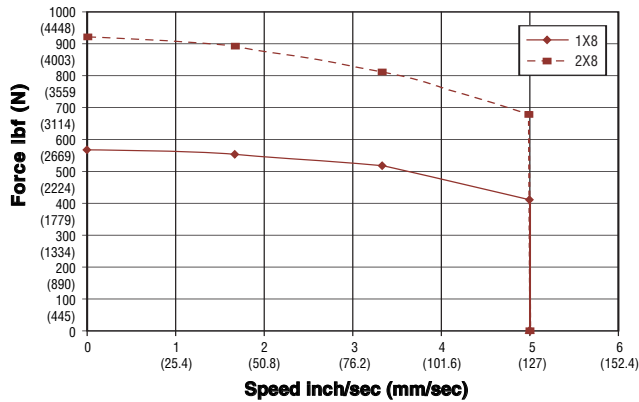

EL30-.5 Inch Lead

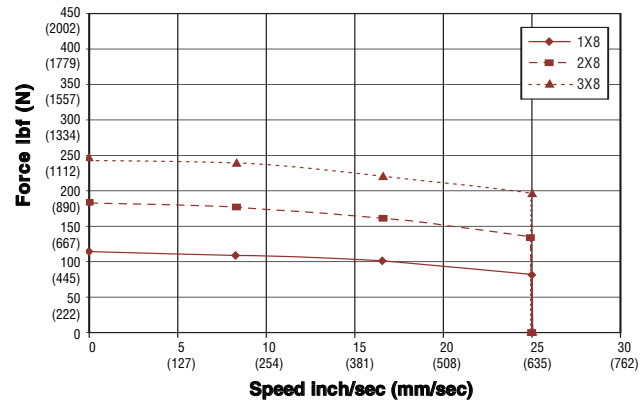

EL Series

EL30 Performance Specifications

Model No.	Frame Size in. (mm)	Stroke in (mm)*	Screw Lead in (mm)	Force Rating 1 stack/ 2 stack lb (N)	Max. Velocity in/sec (mm/sec)	Approx.* Cont. Motor Torque 1 stack/ 2 stack lb-in (Nm)	Maximum Static Load lb (N)	Armature Inertia Rating** Lb-in-s ² (Kg-m ²)	Dynamic Load lb (N)	Weight (approx) lb (Kg)
EL30-0301	3.125 (79.0)	3 (75.0)	0.1 (2.54)	543/885/NA (2415/3936/NA)	5 (127.0)	10.8/17.6/NA (1.22/1.99/NA)	2700 (12010)	0.00319 (0.00036)	5516 (24536)	12 (5.4)
EL30-0302	3.125 (79.0)	3 (75.0)	0.2 (5.08)	271/442/NA (1205/1966/NA)	10 (254.0)	10.8/17.6/NA (1.22/1.99/NA)	2700 (12010)	0.00319 (0.00036)	5800 (25798)	12 (5.4)
EL30-0305	3.125 (79.0)	3 (75.0)	0.5 (12.7)	109/177/NA (485/787/NA)	25 (635.0)	10.8/17.6/NA (1.22/1.99/NA)	2700 (12010)	0.00319 (0.00036)	4900 (21795)	12 (5.4)
EL30-0601	3.125 (79.0)	6 (150.0)	0.1 (2.54)	543/885/NA (2415/3936/NA)	5 (127.0)	10.8/17.6/NA (1.22/1.99/NA)	2700 (12010)	0.00361 (0.00041)	5516 (24536)	15 (6.8)
EL30-0602	3.125 (79.0)	6 (150.0)	0.2 (5.08)	271/442/626 (1205/1966/2785)	10 (254.0)	10.8/17.6/24.9 (1.22/1.99/2.81)	2700 (12010)	0.00361 (0.00041)	5800 (25798)	15 (6.8)
EL30-0605	3.125 (79.0)	6 (150.0)	0.5 12.7	109/177/250 (485/787/1112)	25 (635.0)	10.8/17.6/24.9 (1.22/1.99/2.81)	2700 (12010)	0.00361 (0.00041)	4900 (21795)	15 (6.8)

*Please note that stroke mm are nominal dimensions. **Inertia +/- 5%.

For definition of terms see page 13.

EL30 Series Mechanical / Electrical Specifications

		EL30															
Maximum Backlash (not pre-loaded)	in (mm)	0.004 (.10)															
Maximum Backlash (pre-loaded)	in (mm)	0.0															
Lead Accuracy	in/ft (mm/300 mm)	0.001 (.025)															
Maximum Radial Load	lb (N)	30 (134)															
Environmental Rating: Standard		IP65															
MOTOR STATOR – T4 Ratings		1A8	1B8	118	138	158	168	2A8	2B8	218	238	258	268	318*	338*	358*	368*
RMS Sinusoidal Commutation																	
Continuous Motor Torque**	lbf-in	10.8	10.8	10.9	10.8	10.7	10.3	17.4	17.4	17.6	17.6	17.5	17.5	25.2	24.9	23.6	23.6
(+/- 10% @ 80°C)	(N-m)	(1.22)	(1.22)	(1.23)	(1.22)	(1.21)	(1.16)	(1.97)	(1.97)	(1.99)	(1.99)	(1.98)	(1.98)	(2.85)	(2.81)	(2.67)	(2.67)
Torque Constant (Kt)**	lbf-in/A	1.1	1.1	4.4	8.7	15.5	17.5	1.1	1.1	4.4	8.7	15.5	17.5	4.4	8.7	15.7	17.6
(+/- 10% @ 80°C)	N-m/A	(0.13)	(0.13)	(0.49)	(0.99)	(1.75)	(1.98)	(0.13)	(0.13)	(0.49)	(0.99)	(1.75)	(1.98)	(0.50)	(0.98)	(1.77)	(1.98)
Continuous Current Rating**	Amps	10.7	10.7	2.8	1.4	0.8	0.7	17.3	17.3	4.5	2.2	1.3	1.1	6.3	3.2	1.7	1.5
Peak Current Rating	Amps	21.3	21.3	5.6	2.8	1.5	1.3	34.5	34.5	9.0	4.5	2.5	2.2	12.7	6.4	3.4	3.0
Trapezoidal Commutation																	
Continuous Motor Torque**	lbf-in	10.3	10.3	10.4	10.3	10.2	9.8	16.6	16.6	16.8	16.8	16.7	16.7	24.1	23.8	22.5	22.6
(+/- 10% @ 80°C)	(N-m)	(1.16)	(1.16)	(1.17)	(1.17)	(1.15)	(1.11)	(1.88)	(1.88)	(1.90)	(1.90)	(1.89)	(1.89)	(2.72)	(2.69)	(2.55)	(2.55)
Torque Constant (Kt)**	lbf-in/A	0.9	0.9	3.4	6.8	12.1	13.6	0.9	0.9	3.4	6.8	12.1	13.6	3.5	6.8	12.2	13.7
(+/- 10% @ 80°C)	(N-m/A)	(0.10)	(0.10)	(0.39)	(0.77)	(1.37)	(1.54)	(0.10)	(0.10)	(0.39)	(0.77)	(1.37)	(1.54)	(0.39)	(0.76)	(1.38)	(1.55)
Continuous Current Rating	Amps	13.1	13.1	3.4	1.7	0.9	0.8	21.1	21.1	5.5	2.8	1.5	1.4	7.8	3.9	2.1	1.8
Peak Current Rating	Amps	26.1	26.1	6.8	3.4	1.9	1.6	42.3	42.3	11.0	5.5	3.1	2.7	15.5	7.9	4.1	3.7
Motor Stator Data																	
Voltage Constant (Ke)**	Vrms / Krpm	7.7	7.7	29.9	59.7	106.0	119.5	7.7	7.7	29.9	59.7	106.0	119.5	30.3	59.2	106.9	119.9
(+/- 10% @ 80°C)	Vpk / Krpm	10.9	10.9	42.2	84.5	149.9	168.9	10.9	10.9	42.2	84.5	149.9	168.9	42.9	83.8	151.2	169.6
Pole Configuration		8	8	8	8	8	8	8	8	8	8	8	8	8	8	8	8
Resistance (L-L) (+/- 5% @ 80°C)	Ohms	0.19	0.19	2.8	11.2	36.3	49.6	0.08	0.08	1.1	4.5	14.1	18.0	0.65	2.6	9.3	11.6
Inductance (L-L)(+/- 5%)	mH	0.51	0.51	7.7	30.7	96.8	123.0	0.24	0.24	3.7	14.7	46.2	58.7	2.5	9.5	30.9	38.8
Mech Time Constant (tm)	ms min	6.6	6.6	6.5	6.5	6.7	7.2	2.6	2.6	2.6	2.6	2.6	2.6	1.5	1.5	1.7	1.7
	Max	7.4	7.4	7.3	7.4	7.6	8.1	3.0	3.0	2.9	2.9	3.0	3.0	1.7	1.7	1.9	1.9
Electrical Time Constant (te)	ms	2.7	2.7	2.8	2.7	2.7	2.5	3.2	3.2	3.3	3.3	3.3	3.3	3.8	3.7	3.3	3.3
Damping Constant	lbf-in/krpm	1.23	1.23	1.23	1.23	1.23	1.23	1.23	1.23	1.23	1.23	1.23	1.23	1.23	1.23	1.23	1.23
	(N-m/krpm)	(0.14)	(0.14)	(0.14)	(0.14)	(0.14)	(0.14)	(0.14)	(0.14)	(0.14)	(0.14)	(0.14)	(0.14)	(0.14)	(0.14)	(0.14)	(0.14)
Friction Torque	lbf-in	2.00	2.00	2.00	2.00	2.00	2.00	2.00	2.00	2.00	2.00	2.00	2.00	2.00	2.00	2.00	2.00
	(N-m)	(0.23)	(0.23)	(0.23)	(0.23)	(0.23)	(0.23)	(0.23)	(0.23)	(0.23)	(0.23)	(0.23)	(0.23)	(0.23)	(0.23)	(0.23)	(0.23)
Bus Voltage	Vrms	24VDC	48VDC	115	230	400	460	24VDC	48VDC	115	230	400	460	115	230	400	460
Speed @ Bus Voltage	RPM	1500	3000	3000	3000	3000	3000	1500	3000	3000	3000	3000	3000	3000	3000	3000	3000
Motor Wire Insulation		Class 180H															
Temperature Class	°C	T4 = 135°C								T3A = 180°C							
Connectors		Potted NPT Connectors Only															

For amplifiers using peak sinusoidal ratings, multiply RMS sinusoidal Kt by 0.707, and current by 1.414.
Specifications reflect 80°C test environment

*Not available with 3" stroke

Specifications subject to change without notice.

**For T3A Temperature Class multiply Kt & Ke ratings by 0.83; Continuous Current by 1.245; Continuous Torque by 1.095

Actuator Rod End Options

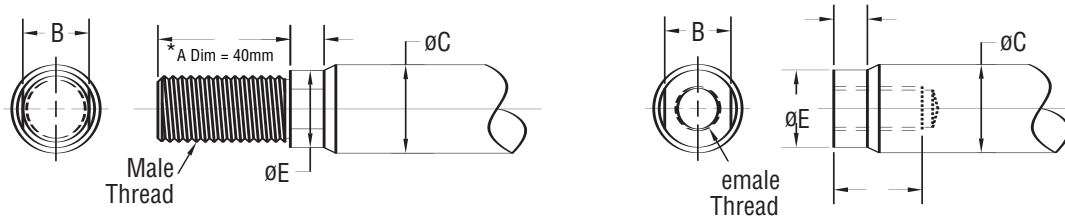

	A	B	øC	D	øE	F	Male U.S.	Male Metric	Female U.S.	Female Metric	
EL30	in (mm)	0.750 (19.1)	0.500 (12.7)	0.625 (15.9)	0.281 (7.1)	0.562 (14.3)	0.750 (19.1)	7/16 - 20 UN F- 2A	M12X1.75* 6g	7/16 - 20 UNF - 2B	M10X1.5 6h

EL30 Clevis Mount

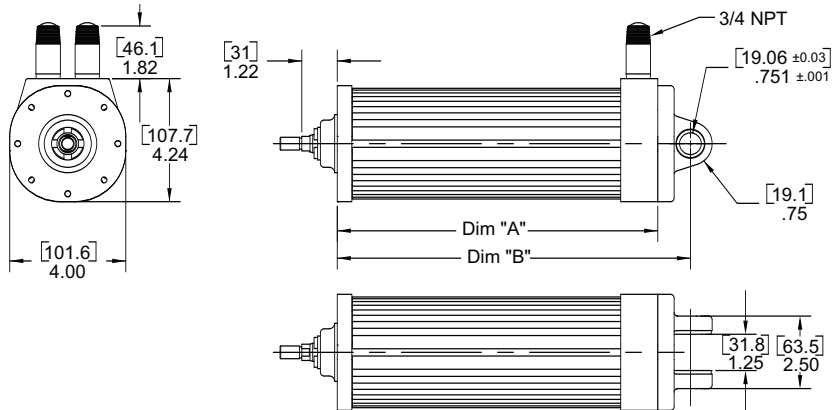

EL30 Front Flange Mount

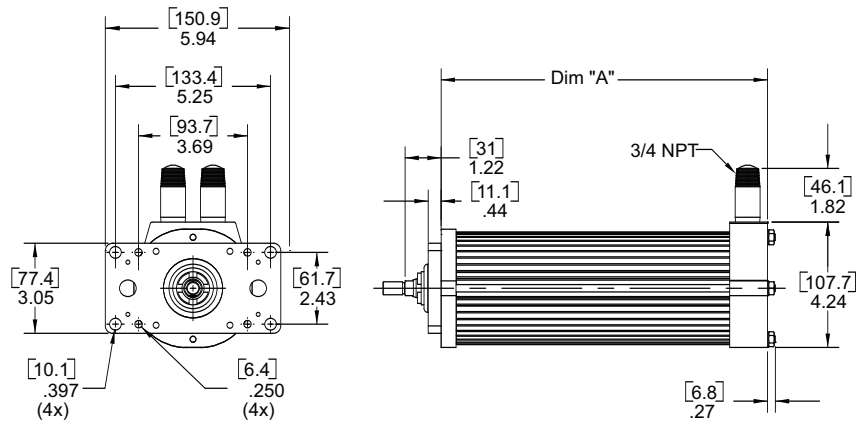

EL30 Base Unit

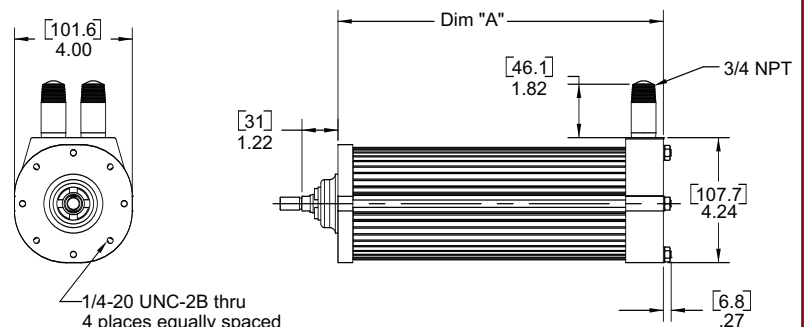

Dim	3" (76.2 mm) stroke	6" (152.4 mm) stroke
A	8.6 (218)	11.0 (281)
B	9.7 (246)	12.2 (309)

1/4-20 UNC-2B thru
4 places equally spaced
on ø3.536 B.C.

<h2>EL30 Series Ordering Information</h2>	ELAA - BBCC - DDDEF - GGG - HHH - II - JJJ - XX - #####																	
<p>EL = Model Series EL = EL Series</p>	<p>GGG = FeedbackType (Also specify the Amplifier/Drive Model being used when ordering) -Standard Resolver – Size 15 1024 line (2068 cts) per rev, two phase resolver XX1 = Custom Feedback – Wiring and feedback device information must be provided and new feedback callout will be created – Please consult application engineering: 001 = Feedback Mount Only – .375 inch shaft ready for size 15 resolver 002 = Feedback Mount Only – 8 mm shaft ready for feedback device AB6 = Allen-Bradley/Rockwell – Standard Resolver AM3 = Advanced Motion Control – Standard Resolver AP1 = API Controls – Standard Resolver BD2 = Baldor – Standard Resolver BM2 = Baumuller – Standard Resolver BR1 = B&R Automation – Standard Resolver CO2 = Copley Controls – Standard Resolver DT2 = Delta Tau Data Systems – Standard Resolver EL1 = Elmo Motion Control – Standard Resolver EM4 = Emerson/Control Techniques – Standard Resolver EX4 = Exlar – Standard Resolver IF1 = Infranor – Standard Resolver IN6 = Indramat/Bosch-Rexroth – Standard Resolver JT1 = Jetter Technologies – Standard Resolver KM5 = Kollmorgen/Danaher – Standard Resolver LZ5 = Lenze/AC Tech – Standard Resolver MD1 = Modicon – Standard Resolver MG1 = Moog – Standard Resolver MX1 = Metronix – Standard Resolver OR1 = Ormec – Standard Resolver PC7 = Parker – Standard Resolver – European only PC0 = Parker – Standard Resolver – US Only PS3 = Pacific – Scientific Standard Resolver SM2 = Siemens – Standard Resolver SW1 = SEW/Eurodrive – Standard Resolver WD1 = Whedco/Fanuc – Standard Resolver</p>																	
<p>AA = Frame Size 30 = 3 inch nominal</p>	<p>HHH = Motor Stator</p> <table border="0" style="width: 100%;"> <tr> <td>1A8 = 1 stack, 24 Vrms, 8 pole</td> <td>218 = 2 stack, 115 Vrms, 8 pole</td> </tr> <tr> <td>1B8 = 1 stack, 48 Vrms, 8 pole</td> <td>238 = 2 stack, 230 Vrms, 8 pole</td> </tr> <tr> <td>118 = 1 stack, 115 Vrms, 8 pole</td> <td>258 = 2 stack, 400 Vrms, 8 pole</td> </tr> <tr> <td>138 = 1 stack, 230 Vrms, 8 pole</td> <td>268 = 2 stack, 460 Vrms, 8 pole</td> </tr> <tr> <td>158 = 1 stack, 400 Vrms, 8 pole</td> <td>318 = 3 stack, 115 Vrms, 8 pole*</td> </tr> <tr> <td>168 = 1 stack, 460 Vrms, 8 pole</td> <td>338 = 3 stack, 230 Vrms, 8 pole*</td> </tr> <tr> <td>2A8 = 2 stack, 24 Vrms, 8 pole</td> <td>358 = 3 stack, 400 Vrms, 8 pole*</td> </tr> <tr> <td>2B8 = 2 stack, 48 Vrms, 8 pole</td> <td>368 = 3 stack, 460 Vrms, 8 pole*</td> </tr> </table>		1A8 = 1 stack, 24 Vrms, 8 pole	218 = 2 stack, 115 Vrms, 8 pole	1B8 = 1 stack, 48 Vrms, 8 pole	238 = 2 stack, 230 Vrms, 8 pole	118 = 1 stack, 115 Vrms, 8 pole	258 = 2 stack, 400 Vrms, 8 pole	138 = 1 stack, 230 Vrms, 8 pole	268 = 2 stack, 460 Vrms, 8 pole	158 = 1 stack, 400 Vrms, 8 pole	318 = 3 stack, 115 Vrms, 8 pole*	168 = 1 stack, 460 Vrms, 8 pole	338 = 3 stack, 230 Vrms, 8 pole*	2A8 = 2 stack, 24 Vrms, 8 pole	358 = 3 stack, 400 Vrms, 8 pole*	2B8 = 2 stack, 48 Vrms, 8 pole	368 = 3 stack, 460 Vrms, 8 pole*
1A8 = 1 stack, 24 Vrms, 8 pole	218 = 2 stack, 115 Vrms, 8 pole																	
1B8 = 1 stack, 48 Vrms, 8 pole	238 = 2 stack, 230 Vrms, 8 pole																	
118 = 1 stack, 115 Vrms, 8 pole	258 = 2 stack, 400 Vrms, 8 pole																	
138 = 1 stack, 230 Vrms, 8 pole	268 = 2 stack, 460 Vrms, 8 pole																	
158 = 1 stack, 400 Vrms, 8 pole	318 = 3 stack, 115 Vrms, 8 pole*																	
168 = 1 stack, 460 Vrms, 8 pole	338 = 3 stack, 230 Vrms, 8 pole*																	
2A8 = 2 stack, 24 Vrms, 8 pole	358 = 3 stack, 400 Vrms, 8 pole*																	
2B8 = 2 stack, 48 Vrms, 8 pole	368 = 3 stack, 460 Vrms, 8 pole*																	
<p>BB = Nominal Stroke Length 03 = 3 inch stroke 06 = 6 inch stroke XX = Special stroke not to exceed 6 inches</p>	<p>II = Motor Speed 01 - 99 = Two digit number - rated speed in rpm x 100</p>																	
<p>CC = Screw Lead 01 = 0.1 inch lead 02 = 0.2 inch lead 05 = 0.5 inch lead XX = Special</p>	<p>JJJ = Hazardous Location Temperature Rating T3A = 180 deg C (Samarium Cobalt magnets) T4 = 135 deg C (Neodymium-Iron-Boron magnets)</p>																	
<p>DDD = Connector Options N## = Potted NPT with flying leads X## = length of flying leads in feet</p>	<p>XX = Optional Speed & Mechanical Designations -Multiples possible XL = Special lubrication PF = Preloaded follower¹ XT = Special travel option</p>																	
<p>E = Mounting Options F = Front Flange C = Rear Clevis H = Threaded Face X = Special Mounting</p>	<p>##### = Part Number Designator for Specials ##### = Optional 5 digit assigned part number to designate unique model number for specials</p>																	
<p>F = Rod Ends M = Male, US std thread A = Male, Metric std thread F = Female, US std thread B = Female, Metric std thread X = Special rod end</p>	<p>Notes: 1. The dynamic load rating of zero backlash, preloaded screws is 63% of the dynamic load rating of the standard non-preloaded screws. The calculated travel life of a preloaded screw will be 25% of the calculated travel life of the same size and lead of a non-preloaded screw. Preloaded follower is not available with absolute internal feedback option.</p>																	
<p>*Not available with 3" stroke</p>																		